

The Legend of Lorelei

Volume 49, Issue 3

May-June 2020



Welcome to the 2020 "Covid - Tornado - Boating" Issue

We are publishing the Calendar today, knowing that some of our fun summer events and committee/club meetings may not happen as planned. Please look for announcements on the Electronic Board at the front of the lake, Facebook postings, and possible emails from the Board of Trustees or your committee chairs. It is a good idea to check with each Committee or the Lake Office if you have any questions. Those contact names are presented later in this newsletter for your convenience.

You will notice that some of the more light-hearted articles are missing this issue so that we could cover more boating and lake information; they will be back. At least we all can enjoy the lake this summer!

REMEMBER to follow all Ohio restrictions, and Lake Rules & Regulations for our health and safety.

Calendar

NOTE: All committee meetings/activities are tentative and may meet in the Pavilion this summer - check with the organizers.

May



16	Lake Lorelei Day at John's Flowers	9:00 AM - 6:00 PM	
19	Tuesday Fishing	6:00 - 9:30 PM	Marina
21	BOT Quarterly Meeting	7:00 PM	Clubhouse
30	Spring Fishing Tournament	7:00 AM - 3:00 PM	Marina

June



1	Water Quality Meeting	6:00 PM	Clubhouse
2	Tuesday Fishing	6:00 - 9:30 PM	Marina
4	Women's Club Meeting	7:00 PM	Clubhouse
8	PRIDE Meeting	7:00 PM	Clubhouse
9	Fireworks Committee Meeting	7:00 PM	Clubhouse
11	Activities Committee Meeting	7:30 PM	Clubhouse
16	Tuesday Fishing	6:00 - 9:30 PM	Marina
20	Poker Boat Run	6:00 PM	Marina/Pavilion
27	Kid's Fishing Tournament	5:30 - 8:00 PM	Marina

July

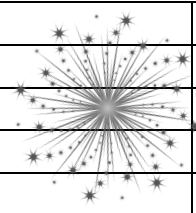

2	Women's Club Meeting	7:00 PM	Clubhouse
4	FIREWORKS!!	Sundown	over the Dam
6	Water Quality Meeting	6:00 PM	Clubhouse
7	Tuesday Fishing	6:00 - 9:30 PM	Marina
9	Activities Committee Meeting	7:30 PM	Clubhouse
13	PRIDE Meeting	7:00 PM	Clubhouse

Next Issue Adv/Copy Due: June 17, 2020

Board of Trustees - President's Report

Mike Hopkins, President BOT

I want to thank all our members for their cooperation and understanding during the State of Ohio's **stay at home and social distancing** requirements. The Board of Trustees will continue to keep everyone informed as we move forward through this crisis.



On top of dealing with COVID-19, late Wednesday night April 8, Lake Lorelei was hit with a tornado and high winds. There was a lot of property damage, hundreds of trees on the ground and power/utility lines down throughout the community. Before the wind even died down, the Fayetteville/Perry Fire Department was on our roads cutting trees and opening the main roads for emergency vehicles. The fire department members weren't the only volunteers out that night. Our neighbors and fellow members were out in the wind, rain, and downed power lines clearing roads and helping their neighbors. Some of these volunteers had to work that next morning. At daybreak, our maintenance department mobilized our equipment and started to clear the side roads.



As hard as our maintenance guys worked, they would not have accomplished this task without all the volunteers who jumped in to help. Kudos to members helping members; to the people that brought drinks and food to the volunteers and other members in need; to the home owners that paid contractors to take care of their property and had the contractors clear roads and common areas at their expense; to the contractors that helped clear roads and common areas free of charge; and to our members that responded to emergency requests and rotated generators for our members in need. I am very thankful that we suffered no casualties.



As a community, we have our usual disagreements....member vs. member or member vs. Board...this is normal. But when we have a common adversity or enemy, we do unite and work together. I am calling on this solidarity to correct another problem in our community.

We have a few knuckleheads living in our community that have no fear of authority or respect for any of their neighbors. The Board has been proactive in trying to mitigate the problem. We have issued fines when justified, and the Brown County Deputies have made several arrests.

We do listen to the requests of our members. The hours of our guards have been extended two hours at night and I have tried to establish a Neighborhood Watch program for four months now. I have sent three emails and made two phone calls before I got a response that said, the Brown County Sheriff is occupied with the COVID-19 and will get back to us. I know our sheriff's department is doing the best they can with the resources they have available.

I have asked Trustee Greene to spearhead the Neighborhood Watch initiative (see her article later in this issue). I don't want a vigilante type of response or anyone to put themselves in harm's way. What would help most is to note the time, date and take photos of any activity that is considered unusual.

I am so grateful to be given the opportunity to live in such a unique community.

Contact the entire Board of Trustees with one email address:
board.trustees@lakeloreleiohio.com



Captain's Cove

(513) 321-1111

**301 Washington St.
 New Richmond, OH 45157**

FULL SERVICE DEPT.

- Certified Mercury & Volvo
- Suzuki Service
- Canvas & Upholstery
- Parts & Accessories
- Detail Service

**New Location!
 Closer to the Lake!**



GLASTRON

Large Selection of
Pre-Owned Boats

**Your Local Dealer
 with the
 Right Boats
 for Your Lake!**



Bentley
PONTOONS



Way of Life!



MERCURY
 MerCruiser

VOLVO
 PENTA

www.captainscovemarine.com

Lake Safety Rules



LLPOA Board of Trustees

Soon the boating season will be here and we hope that everyone has a safe and enjoyable one. Remember that our lake is not only governed by the rules of the state of Ohio in regards to boating but we also have rules specific to our lake.

Here is just a brief summary of some of those rules along with suggestions for safer boating this summer. A complete list of the rules can be found on our website or at the office.

Most importantly remember that **Children under the age of 12** may not operate a PWC (e.g., Jet Ski, Sea-Doo, etc.), under any circumstances. Children ages 12 to 15 may operate only if they have an education certificate* and there is an adult (18 or older) on board with them. Young adults age 16 and older may operate if they have an education certificate*.



**In addition, Ohio law requires all motorized boat and PWC operators born after January 1, 1982, who will be operating a vessel over 10 hp., to pass a boater safety course and to carry a boater education card.*

➤ All watercraft to be operated on the lake must be registered by the Association and display a current LLPOA decal affixed to the stern and your 3" Lot #'s displayed on both the left & right of your watercraft's stern above the waterline.

➤ All Boaters must Maintain a Counter-Clockwise Direction (shoreline on right)

➤ Towing multiple skiers, wakeboarders or more than one device such as a tube, surfboard, or similar device simultaneously is prohibited from 10:00 A.M. to 5:00 P.M., on Saturdays, Sundays, and Holidays.



➤ The use of wake enhancing devices and/or wake surfing is prohibited from 10:00 A.M. to 5:00 P.M., on Saturdays, Sundays, and Holidays. Wake surfing is prohibited (completely – at all times) behind any watercraft with an inboard/outboard motor (stern drive) or an outboard motor.

➤ Maximum Speed on LAKE LORELEI

◆ 35 MPH—Sunrise to Sunset

◆ 6 MPH—Sunset to Sunrise Water-Ski / Open Zone Maximum Speeds:

◆ Note: As a reminder of this "6 mph" rule, at and after sunset, the LSP patrol boat may be navigating down the center of the lake with its oscillating light in operation.



➤ NO PWC operation after Sunset

➤ ALL coves are no wake zones

➤ Watercraft under power shall not be operated within 20 feet of swimming areas, shorelines or docks or within 150 ft. of marina ramp & gas pump.



➤ Swimming is not permitted from any LLPOA owned shoreline or dock, except at the public swimming areas as provided. Swimming outside the safety line and floats is prohibited.

➤ Swimming in the main lake is limited to twenty feet from shore or dock.

➤ Swimming is prohibited from anchored or drifting boats on the main lake, or outside of any coves and inlets.

All the **CONVENIENCE** of
BANKING at your **FINGERTIPS**

Including
Online Banking
Mobile Banking
Mobile Deposit

Visit us at
www.ncb.coop
or download the
National Coop Bank
mobile app today!



Working Together.
Building Community.

Banking products and services provided by
National Cooperative Bank, N.A. Member FDIC

Let's Plant Trees!

Lee Duncan, Lake Member

Post-tornado, Plant Trees to Keep Our Community Beautiful



According to the National Weather Service, the tornado that impacted many of us on the night of April 8 had sustained winds of around 80 mph when it hit the Lake. It was about 200 yards wide, was on the ground from 10:50 to 11:00 pm, and covered 8.8 miles in total. Fortunately, no one was injured or killed, but our community suffered property damage and a significant loss of trees. (Ref. 1.)

I encourage all of us, even if you didn't lose any trees to the tornado, to consider planting trees! Here is a partial list of the practical benefits of trees:

- Trees hold soil in place, reducing erosion and decreasing the need for future dredging of the Lake (saving us money!).
- Trees produce oxygen and sequester carbon dioxide, helping keep the planet cool. According to the Department of Agriculture, a growing tree's net cooling effect is equivalent to 20 room air conditioners running 20 hours a day. (Ref 2.)
- If you plant a tree today on the west side of your home, in five years your energy bill should be 3% less. In fifteen years, the saving will be nearly 13%. (Ref. 2.)
- Numerous studies have shown how much healthy trees add to property values. For example, Forest Service research shows that trees in the landscape add an average of 10% to your home's value. (Ref 2.)
- Trees provide a home for wildlife, including native birds, butterflies, bees, and other pollinators.
- Studies have shown that just looking at a nice landscape including trees reduces stress and helps hospital patients recover more quickly. (Ref. 3.)

These are all good reasons to consider planting trees. However, the one I consider most important is not listed: Trees are beautiful!

There are several excellent advertisers in the *Legend* who would be eager to help you plan, purchase, and install your new trees. I would also be happy to help if you'd like (lrduncan811@gmail.com). Let's keep our community looking good by planting more trees!

Lee is not an arborist or a professional tree expert, but really, really loves trees. He and his wife, Mary Lynn lost 17 trees in the tornado.

References:

- [1] "April 8-9, 2020, EF0 Tornado Confirmed near Newtonsville / Lake Lorelei, Ohio," *National Weather Service* (Apr. 2020), available at https://www.weather.gov/iln/20200409_lakelorelei.
- [2] "Benefits of Trees," *Arbor Day Foundation*, available at <https://www.arborday.org/trees/benefits.cfm>.
- [3] Deborah Franklin, "How Hospital Gardens Help Patients Heal," *Scientific American* (Mar. 1, 2012), available at <https://www.scientificamerican.com/article/nature-that-nurtures/>.

The Legend wants to hear from you!

Your suggestions and ideas are always welcome.

We will do our best to publish all appropriate content. The Editor reserves the right to make minor copy-editing changes, per accepted standards for punctuation, spelling, capitalization and usage. The Editor may adapt any submitted copy to conform as needed with the current publication layout and design standards.

Email: TheLegend@lakelorelei.ohio.com



Since being licensed as a REALTOR® in 1990,
I have gained the knowledge and compassion to help buyers and
sellers make the right home ownership and investment decisions.
As an owner of waterfront property since 2002, I have a strong
interest in the values and conditions of our community as well.
If I can assist you, please call me.



If you are looking for a “New Shelter in Place”, please give me a call.

I Am Following ALL Recommended Protocol to Keep Buyers & Sellers Safe & Healthy.

Stay Safe... Social Distance... Wash Hands... Sanitize... Get Rest... Eat right... Get Exercise... Laugh... Stay Healthy

Remember, Honor and Be Thankful

Chris Behm
Comey & Shepherd, REALTORS®
(513) 518-2353
chrisbehm1@gmail.com
comey.mobi/BEHM



Fish Committee - Upcoming Events

Tom Iles, Chair

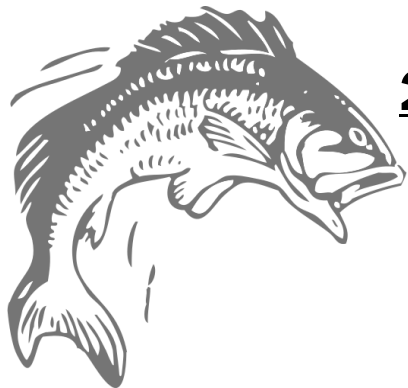

2020 Tournament Schedule & Rules

Dates

May 19th 6-9:30 P.M.	Aug. 4th 6-9:30 P.M.
June 2nd 6-9:30 P.M.	Aug. 18th 6-9 P.M.
June 16th 6-9:30 P.M.	Sept. 1st 6-9 P.M.
July 7th 6-9:30 P.M.	Sept. 15th 6-8:30 P.M.
July 21st 6-9:30 P.M.	

Entry

Entry Fee: \$20.00 Per Team

Individual Fee: \$15.00

\$5.00 Of Entry Will Go Toward Big Bass

Prizes (number of boats competing)

5 Boats Or Less: 1st Place 100%

6-8 Boats 2 Places: 70% & 30%

9 Boats And Up 3 Places: 50%-30%-20%

Spring Tournament - (new) May 30th; 7am - 3pm

Kids Tournament - June 27th; 5:30pm - 8pm

Night Tournament - August 1st; 12am - 8am

Fall Tournament - October 10th; 7:30am - 3:30pm

Tuesday Evening Rules

- ◆ Ties Will Be Resolved In The Following Order:
 - ◇ Largest Number Of Fish, Largest Fish And A Flip Of A Coin
- ◆ A Limit Of 5 Bass Per Person At Least 12 Inches Long, Measured With The Mouth Fully Closed
 - ◇ 10 Bass Per Boat
- ◆ Official Time Will Be Kept. One Person Must Be At The Marina And On The Ground At Official Quitting Time.
- ◆ All Fish must be brought to the scales in a weigh-in bag with sufficient water.
- ◆ All Boats Must Return To The Check-In Site For The Weigh-In.
 - ◇ Teams Or Individuals That Are Late For The Weigh-In Will Be Penalized 1 Pound Per Minute Up To Ten Minutes, Then Disqualified.
- ◆ No Dead Fish Will Be Weighed In.
- ◆ All Property Owners Must Have **2020-21** Stickers On Their Boats.
- ◆ We Understand And Agree That The Lake Lorelei Property Owners Association, Inc., Its Members, Trustees, And Other Participants Are Hereby Waived Of Any Responsibility For Damages, Injury, Or Loss Incurred During This Tournament.
- ◆ No Live Bait Is Allowed.
- ◆ **Be At The Marina at 5:30!!!**

Angler Of The Year Point System

- ◆ Points Will Be Awarded To Individuals for each night of fishing.
- ◆ The End Of The Year Prize Will Be \$100.00 (One Hundred Dollars) Cash And Two Plaques. Paid For By The Fish Committee.
- ◆ Points Will Awarded As Follows:
 - ◇ 5 Points First Place,
 - ◇ 4 Points Second Place,
 - ◇ 3 Points Third Place,
 - ◇ 2 Points For Big Bass. Big Bass Will Be Awarded To Both Individuals No Matter Who Caught The Fish.
 - ◇ 1 Point Will Be Given For Showing Up If You Do Not Place.

INTEGRITY

EXPERIENCE

COMPETENCE

ROBERT L HETTINGER

Certified Public Accountant

**Complete Tax Preparation
IRS and State Tax Resolution**

**39 Years' Experience
Local & Open Year-Round**

**The difference - a real CPA, and...
Exceptional Personal Service**

Why Trust Anyone Else?

120 S Apple Street

(SR 68 between US 50 and the post office)

Fayetteville, Ohio

513-875-4395

roberthettingercpa@gmail.com

Member of The American Institute of Certified Public Accountants

Board of Trustees - Dredging Update

Todd Steinbrink, Trustee

For two and a half years, a group of residents have worked diligently to understand the extent of the work needed to restore our lake and retention areas to their best possible condition along with the methods and costs to do so. They have made every effort to keep everyone informed as it has gone along and there is a great deal of detail contained in the many publications on our website. Since the failed ballot initiative last summer, the group has expanded and continues to further examine the costs and funding options.

A clear majority of those who have responded to our surveys support the need for a dredging program. The challenge becomes agreeing on the most cost effective, yet productive method, along with the means for paying for it. The second survey (to be posted by press time) shows that the community prefers an expedited dredging program over the next three years to address the problem sooner rather than later. Plans include tackling the largest silt deposits, working through every part of the lake, coves and retention ponds to restore them to optimal conditions. Similarly, most agree that once the comprehensive dredging is completed and paid for, that the community should consider a form of ongoing collection effort to prepare for future maintenance needs. It is our intent to put that concept for consideration AFTER we have finished collecting on any approved assessment. That may include a new ongoing assessment like roads, increased boat registrations, etc.; all to be determined at that future time.

Where do we stand today? The current health crisis and tornado response has everything on hold, but our goal has been to return with a proposal for dredging later this year. This will likely combine excavation companies and specialty dredging operators to comprehensively address the problem. Based on estimates from the professional firms that have returned bids, and other lake properties who either have dredged or are contemplating plans, it will cost around \$2.5 million just to remove the silt in all areas. We have brought the \$3 million request to the community because we will need money beyond the simple dredging cost for testing, soil management, remediation/repair work for areas effected by moving equipment and temporary storage, rip rap replacement, as well as interest expense. A plan can be made for any remaining funds if we are able to achieve the desired results for less, so that should not be the concern holding us up from moving forward.

We know this is a very large task for our community and we struggle with the best method for fairly collecting from everyone. This seems to be where the greatest number of differences of opinion are found. Most property owner associations consist of largely homogeneous lots and therefore evenly disperse the costs by lot. In other cases, as amenities are made available equally to every member, the common expense is divided per member. The previous ballot tried to address the diversity of our community by using an individual's property valuation IDENTICAL to the way every other county tax or levy is calculated, but that was rejected by our membership. Our intentions are not to divide the community, but we need to agree to a method that respectfully addresses the differences within our community in a way that is perceived fair to the majority, be that by dwelling and lot, on the water or off, or simply by member.

The reason we have taken our time and collected so much information is to try to get something in front of our community that represents 1) the best plan to address the issue of our greatest asset, which is at significant risk and 2) formulate a means to afford it. Creating an annual fee that is acceptable to the members and using that assessment to borrow the funds necessary to complete the task quickly so we can all enjoy the benefits is the task at hand. Join us in helping to find the solution that threads this needle before it's too late. Otherwise our beautiful lake may be choked out and be at risk of being unusable as other lakes across Ohio have experienced. Let's find a way to agree on how to get in front of this before we all lose.

Lake Lorelei

I hope all of you are well during these difficult times.
The Real Estate market is still very busy and active.
All necessary precautions are being taken during showings.



AVAILABLE

1323-1325 Rhine Drive



AVAILABLE-REDUCED

1232 Lorelei Drive



PENDING

295 Lorelei Drive



PENDING

437 Lorelei Drive



SOLD

1200 Harz Cove



**FULL-TIME LAKE RESIDENT WITH
OVER 75 LAKE LORELEI TRANSACTIONS**

Marcia Greenwald

At Home With Diversity Certification, SRS
Executive Sales Vice President

(513) 503-1573

mgreenwald@sibcycline.com

www.sibcycline.com/mgreenwald



This is not intended to be a form of solicitation if you are working with another broker.

Fayetteville HOUSE OF WORSHIP

We Invite You Sunday Morning
Adult & Children's Bible Study at 9 AM
Worship Service at 10 AM

**During social distancing, join us live on Facebook at 10 AM.*

We have a New Pastor



New Praise & Worship Music

Vacation Bible School

July 20-24; 6:30–8:30 PM for Kids, Pre-school through 6th grade



500 Apple St.

Fayetteville, Ohio 45118

513-875-4055

“Non-Denominational”

Lake Safety Patrol

Pete Zawaly, Volunteer Coordinator

A BIG thank you to Woody Anderson, LLPOA member, for gathering and furnishing this "pre-launch checklist" and the following "required equipment chart" as important reminders to all of us who are boat owners and lake users. Please tear out this sheet to keep. **Safety via Civility!**

Pre-launch Checklist for Safe Boating

- Before launching a boat for the first time each season**, the Ohio Department of Natural Resources Division of Watercraft urges boaters to complete the following checklist to reduce the chances of being unprepared while out on Ohio's waterways.
- Check the boat registration.** ODNR boat registrations are good for three years and expire on March 1. You need to display a valid tag before you put your boat on the water. The registration card or form needs to be carried onboard your boat, as well.
- Check your safety equipment.** Look at the required equipment chart (see next page) to make sure you have all the equipment needed on your boat after it has been stored. The chart also is printed in the Ohio Boat Operator's Guide. Free vessel safety checks usually are offered in the Spring, so you can have a trained opinion.
- Inspect your life jackets.** In addition to making sure you have a properly sized wearable life jacket for each passenger, check each life jacket for mildew, rot and tears in the material, seams and straps. Discard and replace any damaged life jackets.
- Check flares and fire extinguishers.** Buy new flares if their expiration dates have passed, and make sure the fire extinguisher is properly charged.
- Check the first-aid kit.** Replace any supplies that were used last season or have passed the expiration date.
- Check fittings.** Thru-hull fittings below the waterline should be tight; sea valves should operate freely. Make sure the boat plug is on board and in good condition.
- Check for Winter damage.** Inspect non-metallic thru-hulls; they get brittle with age and Winter ice can crack or loosen them. Look for hoses that have been forced off or split from freezing. Every Spring, boats sink at the dock when these problems go undetected until the first heavy rain.
- Check the fuel system.** Inspect fuel fittings and hoses; replace if cracked or showing other signs of stress.
- Check electronic gear.** Get fresh batteries for portable electronic gear, radios, handheld GPS and flashlights. Inspect connections on lights and the horn and other equipment wired into the boat.
- Inspect dock and anchor lines for chafing.** Replace lines if signs of wear are present.
- Check the boat trailer.** Inspect trailer tires for wear and inflate properly. Check the trailer frame for rust spots; inspect the wheel bearings and re-pack if necessary. Test the trailer's lights before towing. Trailer tags renew annually on your birthday, just like your car's license tags. Ohio Bureau of Motor Vehicles
- Check the oil.** Creamy brown or gray engine or driveshaft oil has water in it and a mechanic should find the source of the leak before you start the engine.
- Examine sailboat rigging:** Check for signs of corrosion and wear and for leaks where chain plate mountings come through the deck.
- Check charts and maps.** Be sure your navigational charts and waterway guides are current! Channel markers and buoys change frequently so it is a good idea to update guides every few years.



State of Ohio - REQUIRED BOATING EQUIPMENT

		Non-motorized Watercraft			Motorized Watercraft		
		CANOES KAYAKS SCULLS	ROW BOATS RUBBER RAFTS	PADDLEBOARDS FLOAT TUBES BELLY BOARDS	PERSONAL WATERCRAFT (PWC'S)	LESS THAN 16 FEET	16 FEET LESS THAN 26 FEET
REGISTRATION & NUMBERS <i>ORC 1547.53 (Ohio Revised Code)</i>		X	X		X	X	X
PERSONAL FLOTATION DEVICES <i>ORC 1547.25</i>		X	X	X	X Note 1	X Note 2	X
One type I, II, III or IV device for each person on board							X
One type IV throwable device as an extra							X
FIRE EXTINGUISHER <i>ORC 1547.27</i>					X	X	X
One type B-1							
VISUAL DISTRESS SIGNALS <i>ORC 1547.251</i>					X	X	X
an USGC approved distress flag							
SOUND SIGNALING DEVICE <i>OAC 1501:47-2-33 (Ohio Administrative Code)</i>					X	X	X
a whistle, horn or other device							
ANCHOR & LINE <i>ORC 1547.26</i>			X		X	X	X
LIGHTS <i>OAC 1501:47-2</i>		X	X	X	Note 3	X	X
running lights, electric torch or lantern							
anchor light (displayed at anchor)		X	X	X	Note 3	X	X
VENTILATION <i>ORC 1547.29</i>					X	X	X
engine and fuel tank compartments							
BACKFIRE FLAME ARRESTOR <i>ORC 1547.28</i>					X	X	X
inboard engines							
MUFFLING DEVICE <i>ORC 1547.31</i>					X	X	X
or underwater exhaust							
ENGINE CUTOFF SWITCH LANYARD <i>ORC 1547.41</i>					X		

NOTES:

- 1 Every person on board a PWC must wear a properly fitted life jacket
- 2 On vessels less than 18 feet, any child less than 10 years must wear a properly fitted life jacket
- 3 PWC's are prohibited from operating between sunset and sunrise



For complete Lake Boating Regulations, visit the Lake Lorelei website:
www.lakelorelei.ohio.com

ATTENTION! All LLPOA members in good standing are encouraged to **VOLUNTEER** for one of two positions with the Lake Safety Patrol: **OPERATOR** or **OBSERVER**.

To volunteer, please contact Pete Zawaly at: pzawaly@zawalylaw.com, or call/text 614-216-1798, or chat with one of your neighborhood LSP volunteers; Jan Dooley, Lee & Mary Lynn Duncan, Kathryn Greene, Rick Hosea, Linda Houseworth, Alan Mittermaier, or Cindi Wetzel.

Our motto is **"Safety via Civility!"**



The Lawn Care and Landscaping Professionals
Residential and Commercial properties

***Total Lawn Maintenance ~ New Lawns/Repairs
Full Service Landscaping
Hardscapes/Retaining Walls
Outdoor Paver Patios/Walkways ~ Water Features
Stone Works ~ Shore Repair ~ Beaches
Seasonal Lawn/Bed Maintenance
Fence Install-Vinyl/Split-Rail***

Competitive Rates ~ Fully Insured ~ Free Estimates

Call **Josh** to schedule your free estimate **today!**

(513) 305-5296 or (877) 838-4234

Visit Us Online **www.walkerlandscapeandlawncare.com**

Or email **WLLC@twc.com**

Mention you found us in The Legend of Lorelei for \$\$ OFF Savings for New Customers

Activities Committee - Upcoming Events

Walking or Aerobics
Every Monday, Wednesday, Friday
9:30 AM SHARP!



**Poker Boat Runs
this Summer!**

Saturday, June 20 @ 6 PM
Saturday, August 8 @ 6 PM

Dock Hosts NEEDED!
Contact Michele Hattan

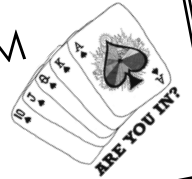

Join Us on 2nd Thursdays, 7:30PM at the LL Clubhouse

Contact:

Pam Haskell-pam.haskell@yahoo.com

Michele Hatton-dickymo4@cinci.rr.com

*Check Out Facebook
for
Pop-Up Events*

Tom Kuebler Carpet & Upholstery Cleaning

25 years experience



**Deep Steaming
Truck mounted equipment**

Living room & Dining room & Hall \$45

Any Five areas \$75

Sofas \$45 · Loveseat \$35 · Chair \$25



**Now offering carpet and upholstery cleaning for
RV's · Motor Homes · Campers · Car Interiors**

Call 513-444-4146

"I clean each carpet like it is my own"

All work guaranteed

Fireworks Committee Update

Marcy Harris, Chair

Lake Lorelei Annual Fireworks

Saturday, July 4, 2020

(rain date Sunday, July 5, 2020)



Mark your calendars, bring your family and friends! This year's firework display will be held at dusk on Saturday, July 4, 2020. We are accepting donations/sponsors now! No amount is too little and all donations/sponsor money will be appreciated and will go toward this year's firework display! If interested please contact Marcy, Amy, Damon, and Craig at:

fireworks.committee@lakeloreleiohio.com

***You can also drop your donation/sponsor money off to the office. Just please put it in an envelope and mark for Fireworks.*

It's time to schedule this year's **BUCKET BRIGADE!** Contact us ASAP to sign up for one-hour shifts, starting at 10 AM.

REMINDER: Summer is coming...don't forget to order your Lake Lorelei apparel at:

<http://RhouseCustom.com/collections/lake-lorelei>

***Note that 25% of ALL sales goes to the Fireworks funds!*

Fisherman's Wharf

At Lake Lorelei

513-875-3332



**Owner/Operators
Barb and Bob Kiley
LLPOA Members since 1970**

Ohio Lottery and Instant Tickets

Bait ~ Ice ~ Beer ~ Gas

ATM



LL Neighborhood Watch Program

Kathryn Greene, Trustee

I wish to take this opportunity to let my fellow members know that we are in the process of reactivating our Neighborhood Watch Program that has been dormant for some time. The mission of this program is to increase the safety of our neighborhood. An NWP accomplishes this by participants adopting more observant and active attitudes. As a result, they become more aware of strange cars, persons, or circumstances.

Fortunately, Lake Lorelei is a very safe neighborhood. I have been a resident since 1979 and observed minimal nefarious behavior here. Being a gated community provides some security but does not begin to address concerns of vandalism, speeding and other activities that endanger persons and property.

Hardly a week goes by without a neighbor posting a notice on Facebook about various misbehaviors that compromise the community's safety and peaceful enjoyment of our property. We believe an active NWP will act as a deterrent for those who would commit offenses against their neighbors. A good NWP is one which assists law enforcement in its efforts to make neighborhoods safer for all property owners by assuming a "brother's keeper" role.

Neighbors are asked to be the eyes and ears in helping police apprehend offenders. It is not intended for the NWP to be a substitute for law enforcement, just a supplement. Further, it is envisioned the NWP participants will work together to identify safety concerns and develop solutions to mitigate them.

We welcome all members of our community to become involved. The NWP is intended to benefit all of us. We need many contributors to make it the kind of program that accomplishes its mission of improving the safety of our neighborhoods.

Please contact me if you are interested in taking an active role in our Neighborhood Watch Program.

Phone: 513-460-4947

Email: kathryn.greene@lakeloreleiiohio.com



Summer Notes

There are NO lifeguards at any public lake swimming area. *Watch your children!*
Golf carts and walkers are out and about - **SPEED LIMIT is 25 MPH.**

ZUGG & Sons Repair SVC. LLC *car care center*

The Next Generation of Automotive Service
Specializing in Automotive Repair

COMPUTERIZED DIAGNOSTIC EQUIPMENT

513-875-2565

4296 St. Rt. 131, Fayetteville

Just 6 Minutes East of Lake Lorelei

Hours: Monday-Friday 10:00-6:00



William Kidwell
Realtor®
NAR
OAR
SOAR

OFFICE: (513) 248-0800
VOICE: (513) 786-9568
CELL: (513) 910-8947
EMAIL: wkidwell@sibcycline.com



1077 State Route 28 • Suite 111 • Milford, Ohio 45150
Web Site: <http://www.sibcycline.com>

John's Flowers

**Summer is Around the Corner!!
Come see us for your planting needs**

2020 Proven Winners!
Large assortment of Annuals & Perennials
Trees ~ Shrubs ~ Bedding
Mulch (Bulk & Bagged) ~ Top Soil
Delivery Available

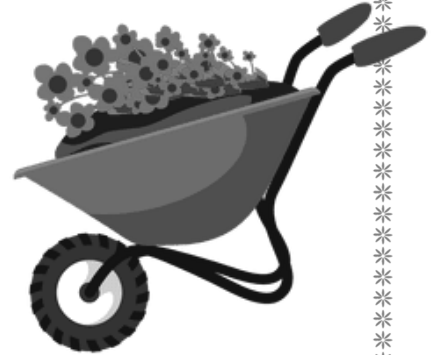

**Nursery & Greenhouse
513-875-3400**

Located on Howard Road ~ 1 mile south of Fayetteville off RT 68

Monday-Saturday 9AM-7PM Sunday 10AM-4PM



alamo
Electronics
Audio/ Video Custom Design & Installation

Serving The Tri State Area Since 1953

(513) 791-2300 – AlamoElectronics.com

Spring is here. Let Alamo design a custom outdoor entertainment system that will provide your family with years of enjoyment.

- Outdoor speakers on sale
- Sonos Wireless Music Systems
- All Weather Outdoor TV Installation
- Home Wi-Fi Networking
- TV Mounting & Installation

9572 Montgomery Road Cincinnati, OH 45242



www.hudepohlheatandair.com
(937) 446-4200
Email: hudyhvac@gmail.com

24 Hour
Emergency
Service

State
License
31213

"A Professional is Not Satisfied Until You Are"

Geothermal Specialist

Sales • Service • Equipment • Replacement

<p>SERVICES</p> <ul style="list-style-type: none"> • Heating • Venting • Air Conditioning • <i>Geothermal Specialist</i> • Heat Pumps • Oil • Gas 	<p>PARTS & ACCESSORIES</p> <ul style="list-style-type: none"> • Programmable Thermostats • Humidifier • High Efficiency Air Cleaners
---	--

Commercial • Residential

Fish Committee Presents

Kids Fishing Tournament

When: JUNE 27th, 2020

Time: 6 PM-8 PM

**Where: Lake Lorelei Marina
Sign up at the Marina on June 27th,**

5:30 PM-6 PM

Who: Ages 1-18



For more details contact:

Tom Iles 513-582-7538

2 Lorelei Dr.

Fayetteville OH, 45118

“Hooked on Fishing Not on Drugs”

D & M Services



Weekly, Bi-Weekly, Monthly
Or One Time Service
Thorough Cleaning Service
FREE ESTIMATES!
(513) 265-4223
dickymo4@cinci.rr.com

Dick & Michele Hatton
Lake Residents

TLC Construction & Design, LLC

Tim Carter, Owner

New Construction
Remodeling/Additions

- Kitchen Cabinets
- Bathrooms
- Ceramic Tile
- Hardwood Flooring Installation



513-383-2941 (Cell) timcrtr7@aol.com

DEN'S BODY SHOP

Collision & Mechanical Specialists
513-875-2652

CELEBRATING 59 YEARS IN BUSINESS

- ◆ Collision Repairs
- ◆ Frame and Unibody Repairs
- ◆ Tires – All Brands ◆ Brake Services
- ◆ Rotor Matching to Hubs to Eliminate Brake Pulsation Permanently
- ◆ Air Conditioner Service
- ◆ Cooling System Maintenance
- ◆ Automatic Transmission Service
- ◆ Lube, Oil and Filter Changes
- ◆ Muffler and Exhaust Service
- ◆ Headlamp Aiming with State-of-the-Art Equipment
- ◆ Computer 4-Wheel Alignment
- ◆ Local Towing ◆ Engine Tune-ups

262 North Apple Street (US 68)
Fayetteville, OH 45118

WE ARE YOUR ONE-STOP AUTO REPAIR SHOP!

WITHAMSVILLE WINNENSON PLUMBING SUPPLY

753-1121

FAX: (513) 753-3130

- * **WATER HEATERS**
- * **FAUCETS AND FCT. PARTS**
- * **TOILETS AND TOILET PARTS**
- * **TUBS AND WHIRLPOOLS**
- * **SHOWERS AND ENCLOSURES**
- * **PIPES, VALVES AND FITTINGS**
- * **DELIVERING TO LAKE LORELEI**

MON-FRI 7:30-5:00
SAT 9:00-1:00

LOTS MOWED / BUSH HOGGED

Residential and open lot
mowing
Brush Removal • Weed
trimming
Other lawn work requests

**All services and fees
are negotiable**



**Please Call
Doug Schmees**

Home: 513-875-2410
Cell: 513-827-1436

Lake Office Update

Kevin Keister, Member Coordinator

Office interaction during the Covid 19 mandate

The Ohio Mandate on distancing has reduced us to one person handling lake registration in the office. Contact us with any questions, concerns or to discuss lake business and payments. We have set up a large drop box on the office deck to exchange documents and decals through the 9-5 business day. We can often fulfill your request with a little pre-planning communication in fairly short order. You can also drop paperwork and fees in the locked drop box on the office ramp during off hours.

Registering watercraft through the Ohio Department of Natural Resources

Lake Lorelei will issue decals to members in good standing with receipt of current ODNR registrations, proof of insurance and titles for powered watercraft. Many members are wondering how to navigate the reduced “face-to-face” business, and if you are registering a new boat or renewing this year, read on.

Breaking press time update: In Person - The Title office in Georgetown is now open to process Title and ODNR needs! The Clerk of Courts – Title division Suite: 2 - 740 Mt Orab Dr., Georgetown, OH 45121. Call ahead, 937-378-0513, with details of your issues, and you can make a single trip!

Email options: The Ohio Department of Natural Resources was *almost* totally shut down at the end of March because of the Ohio Covid – 19 mandate. The normal staff of 20-25 are at home leaving a few administrators in the Columbus DNR offices to process renewal extension vouchers upon request via email. Try these emails and other links concerning your situation and they *may* send you an extension or temporary for a new boat, voucher:

denise.knisley@dnr.state.oh.us; or lacey.harrier@dnr.state.oh.us; watercraft@dnr.ohio.gov.

We’ve received a few vouchers extending expiring registrations to June 30th. You can also call LuAnn normally in the East Fork office @ 513-734-2730 X230 for help.

If you renew on-line you may receive a confirmation email which we can accept as proxy to issue your decals. We ask that you forward the usual 2” X 3” ‘card-like’ document that you’ve typically received once you do receive it. We ask you to carry these vouchers while the ODNR processes the back log of registration requests.

I appreciate everyone’s flexibility and I’m happy to receive any better information you can send to me and we’ll share it throughout the community.

RJC

FLOORING & CONSTRUCTION

Hardwood Installation, Refinishing, Tile, Laminate
& General Construction

(513) 233-5581

1685 Lorelei Dr.
Fayetteville, Ohio 45118

Jared Clem
Owner

RJCFlooring@gmail.com

Free Estimates

“Gravel Guy” Trucking & Bobcat Service



Gravel, Soil, Sand, Mulch Delivered
Grading, Clean-up, Driveways, Heavy Use Pads,
Drainage Problems Corrected

513-519-4192



**Amann Brothers
Construction**
Fayetteville, Ohio



Concrete
Driveways
Sidewalks
Porches
Patios
Boat Ramps
Footers
Garage Floors
Basement Floors
Concrete Removal
Concrete Drilling
Concrete Sawing

513-875-8033
513-490-3675
amannbros@gmail.com

Bobcat Work
Gravel Driveways
Fill Dirt
Top Soil
Sod & Seeding
Landscape
Fencing of any kind
Boat Docks
Rip Rap

Free Estimates

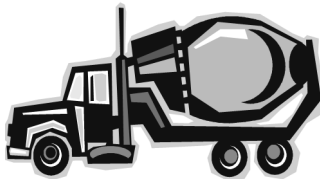

Also Available:
Garage Kits
Pole Barn Kits
&
MORE

Block Retaining Wall
Brick Pavers

Mark Amann

Fritz and Son Plumbing Company

New, Remodeling and Repair

A 25 year Family-owned Business

Lake Lorelei Resident

Call Bob Fritz
563-6526 or 899-2808



Affordable Restorations

513-875-3036 • 513-518-9173

John Eckstein, Jr., Owner



**Lifetime
Warranty
Shingles**

**Did your roof take a HIT this winter?
Let us help you fight back!**

DURATION SHINGLES

- ◆ 130 MPH Wind Warranty
- ◆ 10 YEAR Algae Warranty



Garages • Roofs • Decks
Hardwood and Laminate Floors
Ceramic Tile • Pressure Washing
Gutters • Siding • Patio Doors

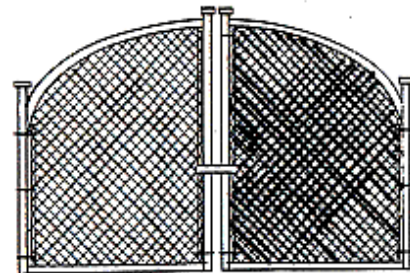

COUCH'S FENCE COMPANY

INDUSTRIAL—RESIDENTIAL
ALL TYPES OF WOOD & CHAIN
LINK

TERRY COUCH
(513) 625-7771
(513) 625-0371 FAX

5414 ST. RT. 133
WILLIAMSBURG
OH 45126

Letter to the Editor

My daughter, Joene, and I live on Eifel Cove. Our property was struck by the tornado, and we lost nine beautiful pine trees that my wife, Beverly, planted fifty years ago. Fortunately, the tornado missed the house by only a couple of feet. The very next day our friends and neighbors from the county and the lake showed up with chain saws and trucks to start the massive clean-up.

From the lake our thanks to Mike & Cindi Wetzel who with Jeff McGlaun arranged generators, which with the help of Chuck Farmer to give us power for three days. Our neighbors the Berkes, sent their son and his buddies to help in the clean-up. The Charltons and the Gregorys also helped us. Lee and Mary Lynn Duncan continue to do so.

Needless to say, our neighbors and friends who live on this beautiful lake have enlarged who we call family.

Bill and Joene Herdman

LLPOA
Watercraft
Powered
2020
20- 0390

ATTENTION ALL BOATERS !

ALL Watercraft on LL must have a LL 2020 Decal.

- ◆ This decal indicates that the boat belongs to a Lake Lorelei Property Owner.
- ◆ Non-powered decals required for canoes, kayaks, paddleboats, and rowboats.

Please do not allow or invite non-members to launch boats at Lake Lorelei.



Lawn, Garden, Farm & Motor Sports

664 W Main St., Blanchester, OH 45107
Phone: 937-783-8330
 Monday-Friday; 9 am to 5 pm
 Saturday; 9 am to 12 pm

Selling the area's largest selection of parts, accessories and equipment for:

*STIHL	*ARDISAM	*KAWASKI
*ARIENS/GRAVELY	*BERCOMAC	*BRIGGS
*TORO	*CAMPBELL	*KOHLER
*SCAG	HAUSFELD	*HONDA
*DR POWER	*GENERAC	*TECUMSEH
*HUSQVARNA	*HAMMERHEAD	*YAMAHA
*BRANSON	GO-KARTS	*GRASSHOPPER
*VORTEX	*CUMBERLAND	*TRAEGER

Parts & service available for most other makes & models of lawn & garden equipment

Financing Available / Pick up & Delivery Available

www.caplingersalesandservice.com
 EMAIL: caplingersales@gmail.com



The Lorelei Café

(513) 875-4992

- ◆ Dine In
- ◆ Carry out
- ◆ Delivery

Join us for

Breakfast ALL DAY
Pizza & Sandwiches
Daily Specials
& FABULOUS DESSERTS!

OPEN Tuesday thru Sunday



Calling All Photographers:

2021 PRIDE CALENDAR Photo Contest

What: Scenic and/or Fun Lake Pictures

Why: PRIDE Calendar

When: Send pictures now thru Sept.30,2020

Where: PRIDEpics@lakeloreleiohio.com

Winner: **Best Photo Wins Installed PRIDE Mailbox**

Fayetteville Hardware & Supply, LLC



TOOLS
PARTS
NEW & USED EQUIPMENT



19535 U.S. 68
Fayetteville, Ohio 45118

Tel. (513) 875-3030
Fax (513) 875-2371

Den's Used Golf Cart Sales

Accessories ♦ Delivery
Customizing
Upon Request

Den's Body Shop
262 North Apple Street
(US 68)
Fayetteville, OH 45118

(513) 875-2652



Vertical Boat Lifts
HIGHEST QUALITY!
LOWEST PRICES!

Ohio Boat Lift, LLC

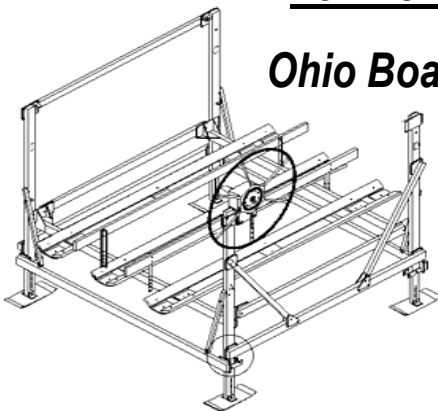

Dealer for Lakeside Lift Corp.
Pete Zawaly, Lake Lorelei

Call: 614-216-1798 or
Email: peter@ohioboatlift.com

Visit: www.lakesidelift.com



Hair Salon & Day Spa, LLC.

Tue 3pm-8pm ~ Wed-Fri 9am-8pm
Sat 9am-3pm

At the intersection of US-50 and SR-131
19426 Vera Cruz Road
Fayetteville, OH 45118

513-875-3000

Full Service Salon

**We can't wait to see
you again!**

"NOW HIRING"

Lake Manager's Report

Steve Ackman

Synopsis of the 2019-2020 Annual Report

The GM's annual report to the board, and to the membership, is a document running in excess of 20 pages. Due to cancellation of the Annual Meeting in April, the 2019 report was not distributed. In this issue of the Legend the general narrative of that report is given to provide a sense of how 2019 went, with dollar amounts rounded:

- ◆ Lake Lorelei's situation was improved in the year 2019.
- ◆ Membership numbers are stable compared to 2018, fluctuating slightly, with a 1.2% increase of members in good standing.
 - ◆ We have 846 members. New member initiations in 2019 totaled 70; the second highest in 15 years.
- ◆ Our finances also reflect stability. Total income in 2019 increased by 3% over 2018.
 - ◆ Personnel costs declined by \$57,000 over costs in 2018; a change of 27%.
 - ◆ Operation expenses declined by 18% from 2018 to 2019.
 - ◆ The Reserve for Capital Expenses fund grew \$105,000, or 30% from 2018 to 2019.
- ◆ Our gates operated 364,000 times with 71% of entries using barcodes; little changed from 2018.
- ◆ Building permits were up by 18 (41%), at 62 for a 15-year high.
- ◆ Phone calls to the office declined by 187, still 17% fewer than in 2014. The average number of calls per day is 18. The highest number of calls in a day, in the last ten years was 82 on May 4, 2012.

YOU'VE MADE IT!

How do you make sure that you keep it?

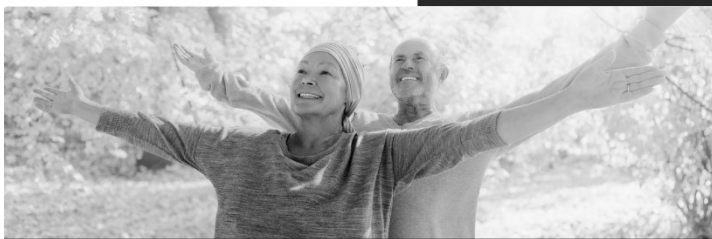

PLAN YOUR RETIREMENT

With a fee-only fiduciary advisor who is required to act in your best interest. For a no-obligation, introductory meeting, contact Dave Wilder, CFP®

TOTAL WEALTH PLANNING

Visit twpteam.com for more information about our firm and additional financial planning and investment management services

513.984.6696 | info@twpteam.com



B&C Total Chimney Care

- ◆ Animal Removal
- ◆ Bird Screens & Caps
- ◆ Damper Repairs
- ◆ Fire Box Masonry Repairs
- ◆ Flashing and Roof Repairs
- ◆ Relining
- ◆ Waterproofing Bricks

Dryer Vent Cleaning

(937) 382-3794
Cell: (937) 302-6131
Colossians: 3:23



Since 1987



First State BANK You're at home with us!

19575 State Route 68
Fayetteville
513-875-8151

FDIC

www.fsb4me.com



- ◆ Road paving was in hiatus in order to build necessary funds for spillway bridge repairs, though seven culverts were replaced at a cost of \$43k.
- ◆ Off-duty Brown County Sheriff Deputies continued patrols within Lake Lorelei in 2019, logging 395 hours and 5,205 road miles.
- ◆ Water quality testing by the Water Quality Committee continued, finding no significant E.Coli contamination.
 - ◆ We continued Fichtelberg and Grunwald water treatments with the professional firm – Aqua Doc.
- ◆ Summer boat patrols continued, combining professional police officers with volunteers to enforce lake rules.
 - ◆ During the season, a total of 34 citations were issued, 7 as fines plus 27 warnings. Cost of operating the boat patrol was \$4,500.
- ◆ Collections continues to be a vexing problem – as it has been for over 40 decades. The board directed inclusion of small claims through the Brown County Municipal Court. This has yielded over \$41,000 in collections and resolved 17 cases to date.
- ◆ Two capital projects were undertaken: replacement of key electrical components of the clubhouse, and grading and significant erosion protection of both banks at the Gladly Run inlet to the main lake.
- ◆ ODNR inspected our dam in March of 2019, with no engineer repair or investigation items reported.

All in all, 2019 was a productive and successful year for LLPOA, advancing many issues on all fronts in positive directions.

JJ Lift Service, LLC.



Sales & Service for
all Hewitt Lifts

Sales Rep for **Hewitt Boat Lifts**
and Accessories

www.hewitt-roll-a-dock.com

Jimmy Johnson

jimmyjohnson@cinci.rr.com

513-875-3715



Sea Ray
CINCINNATI



Sea Ray SPX 190



Harris Solstice 230



Bayliner DX2000



Scarab 195 G Jet Boat

Your New Harris Pontoon Dealer!

Sea Ray BAYLINER *South Bay*
SO WORTH IT!

HARRIS MOOMBA
TOURNAMENT INBOARD BOATS SCARAB

4811 Kellogg Avenue *Cincinnati, OH 45226
513-871-5555 * www.searayofcincinnati.com

Lake Lorelei Property Association Financial Summary

INCOME & EXPENSE SUMMARY MAR 2020

MODIFIED CASH BASIS

*NOTE: a detailed complete financial report is always available in the LL Office

Ordinary Income/Expense

Income		
	Auto Decals	\$38,385.00
	Boat Inspections / Decals	25,570.00
	Dues & Services	152,975.32
	Initiation Fees	3,446.14
	Mowing & Chipping Fees	3,073.60
	Rents and Misc	27,062.72
Total Income		\$250,512.78
Expense		
	Personnel Expenses	
	Wages	\$37,346.33
	Payroll Taxes	4,849.25
	Employee Expenses	1,384.62
	Subcontractors	3,037.50
	Total Personnel Expenses	46,617.70
	Repairs & Maintenance	83,320.20
	Supplies	5,182.43
	Property Taxes	6,514.86
	Utilities	14,657.92
	Other Expenses (Combined)*	37,333.68
Total Expense		\$193,626.79
Excess cash receipts over disbursements		\$56,885.99

*Total Other Expenses (Combined) includes accounting fees, fuel, insurance, postage, printing, professional fees among others

NOTE: Expenses currently do not reflect depreciation expense

ROAD ASSESSMENT ACCOUNT THROUGH 31 MAR 2020

Beginning Balance		\$202,560.73
Road Assessment Collected ¹		54,065.53
Subtotal		256,626.26
Expenditures		
Paving Contractor		0.00
Maintenance ²		4,521.33
Transfer to Ops Labor & Material ³		0.00
Total Expenditures		4,521.33
Ending Balance (as of 31 March)		\$252,104.93

¹ includes building permit collections and Rumpke contribution

²For expenses in support of road repair (culvert replacement, cold patch, salt, etc.)

³For labor or materials dispensed from main account.

NOTE: Beginning balance begins 29 Dec 2018

NOTE: \$102,563.71 in Republic money market fund.

LLPOA Committee and Club Contacts

Activities	Pam Haskell	pam.haskell@yahoo.com
Advisory	Jane Wyman	theadvisorycommittee@lakeloreleiohio.com
Exercise & Fitness		LLEFCemail@gmail.com
Fireworks	Marcy Kuhn Harris	fireworks.committee@lakeloreleiohio.com
Fish	Tom Iles	tomiles1957@gmail.com
Lake Safety Patrol	Pete Zawaly	pzawaly@zawalylaw.com
PRIDE	Brad Brentley	bradbrentley@gmail.com
Roads	Mike Hopkins	mike.hopkins@lakeloreleiohio.com
Water Quality	Chuck Farmer	farmerap42@gmail.com
Women's Club	Irma Divine	msirmadivine@gmail.com



BUY LOCAL!

Support the Legend's Advertisers



- Commercial & Residential -

STUMP REMOVAL • TRIMMING

REMOVAL • LOT CLEARING

EMERALD ASH BORER TREATMENT

CERTIFIED ARBORIST

24-Hour Service

- Free Estimates - Fully Insured -

Earl Boyd
ISA Certified Arborist
 Office: 937-383-3313
 Toll Free: 888-364-6631
 A-1treeohio.com



CONTACT Ernie Reese 24/7!

937-661-4142

513-276-0176

Email: ernie@reesemechanicalheatingandcoolingservice.com

Web: www.reesemechanicalheatingandcoolingservice.com

LIKE us on **FACEBOOK:** REESEMECHANICAL

- We offer **FREE** estimates
- We **NEVER** charge overtime
- We **BELIEVE** in prompt and high quality work

Sales Service Installation

Receive a FREE Condenser & Indoor Coil Cleaning
When you make an appointment for a \$65 Service Check

Have your Cooling System cleaned for Summer!

Contact Ernie Reese 24/7
 (937) 661-4142 or (513) 276-0176
 Like us on Facebook

Additional charges apply to oil furnaces. Other restrictions may apply. Call for Details. Not valid with other offers. Can only be redeemed by Ernie Reese of Reese Mechanical. Offer must be mentioned and redeemed when service check appt. is made. Make appointment by contacting Reese Mechanical.

Welcome New Neighbors!

**Compiled from the LL Office records since the last issue*



Blake Beckett
 Robert C. Brautigam
 Jeremy & Angela Clark
 Robert & Holly Cortelyou
 Shandra Doughman
 Shelby Howell
 Trevor Livingston & Veronica Barrett
 Jeffrey & Tony Mohlman
 Jon Riehle
 Trenton Thompson
 Gary Turner

Brown County Deputy Lake Report

	February 21 - 29	March 1-31	April 1-20
Traffic/Other Citations	0	2	1
Traffic Stops/Warnings	0	0	0
Security Checks	19	99	42
Calls for Ser-	0	5	0

Brown County Deputies are hired to patrol each week, at random times.

Promote your business to Lake Lorelei's members

2019 Advertising Rates
Business Card (3-3/4" x 2-1/4") **\$25**
1/4 Page (3-3/4" x 4-5/8") **\$45**
1/2 Page (7-5/8" x 4-5/8") **\$80**
Full Page (7-5/8" x 9-1/2") **\$150**

Contact: Martha Wallace
 Email: thelegend@lakeloreleiohio.com
 513.257.6230

SAVE THIS NOTICE!

It may save your life

- * Pick up a map at the office and circle your location on the lake (with letters)
- * Determine the SHORTEST distance from Fayetteville to your house – through the **FRONT GATE** or the **BACK GATE**
- * When calling 911, instruct the operator to dispatch the Life Squad through the **FRONT GATE** or **BACK GATE**

**Now that
it's**



Make SURE that you use ALL FOUR digits when dating official documents! If you only use '20", it can be easily changed to another year for fraudulent purposes.

Gate Access:

Access through the gate for visitors is attained in one of two ways:

1. The visitor calls the host using the pedestal at the gate, entering the host four-digit directory number associated with the desired telephone number. The host recognizes the guests as valid and "hits the 9 key" thus ending the conversation and opening the gate.
2. The host obtains a temporary entry code for the visitor and instructs the guest how to use. This method is particularly useful if the host is not accessible by phone or the guest will be with you for more than just a single visit and will be coming and going,

Lake Lorelei Board of Trustees

Embracing the past ~ Managing the present ~ Focused on the future

		Term End	Phone	Email
President	Mike Hopkins	2021	304-8633	mike.hopkins@lakelorelei.ohio.com
Vice-President	Jimmy Johnson	2020	875-3715	jimmy.johnson@lakelorelei.ohio.com
Treasurer	Bob Knueven	2021	875-2299	bob.knueven@lakelorelei.ohio.com
Secretary	John Ipsaro	2021	698-5104	john.ipsaro@lakelorelei.ohio.com
Trustees:	Denis Behm	2022	673-8422	denis.behm@lakelorelei.ohio.com
	Kathryn Greene	2020	460-4947	kathryn.greene@lakelorelei.ohio.com
	Todd Steinbrink	2022	793-9217	todd.steinbrink@lakelorelei.ohio.com
	Cindi Wetzal	2020	875-4874	cindi.wetzal@lakelorelei.ohio.com
	John Wyman	2022	827-0074	john.wyman@lakelorelei.ohio.com



Steve



Kevin



Denise

For more information on Lake Lorelei, visit
www.lakelorelei.ohio.com

Lake Lorelei Office

Phone: **513-875-3435**

Fax: 513-875-4244

General Manager: Steve Ackman
steve.ackman@lakelorelei.ohio.com

Member Coordinator: Kevin Keister
kevin.keister@lakelorelei.ohio.com

Asst. Member Coordinator: Denise Fountain
denise.fountain@lakelorelei.ohio.com

Fall/Winter Office Hours

Monday, Tuesday, Thursday, Friday: 9am-5pm
CLOSED on Wednesdays

*If assistance is needed outside these hours please call
the office and we will make every effort to
accommodate our residents.*

LLPOA accepts



Disclaimer

Any opinion expressed in The Legend reflects only the opinion of the author and not the LLPOA, the Board of Trustees, the staff of The Legend, or any other person.

Advertising in The Legend is not an endorsement of products or services. The Legend staff reserves the right to reject the submissions for publication.

Mission Statement

The Booster Club was organized in 1968 to provide information on official and social activities of interest. The Legend is not an arm of the Board of Trustees but an independent publication approved by the Board of Trustees and is committed to serving the members of the Lake Lorelei Property Owners Association.

The Legend is a private newsletter funded for Lake Lorelei through commercial advertisers.

2020 LLPOA Board Meeting Schedule

JAN	FEB	MAR	APR	MAY	JUN	JUL	AUG	SEP	OCT	NOV	DEC
	Quarterly Meeting		Annual Meeting	Quarterly Meeting	Spring Town Meeting		Quarterly Meeting		Fall Town Meeting	Quarterly Meeting	
No Meet	20 FEB	No Meet	4 APR	21 MAY	6 JUN	No Meet	20 AUG	No Meet	10 OCT	19 NOV	No Meet

The Legend of Lorelei
PO Box 363
Fayetteville, Ohio 45118

PRESORT STD
U.S. POSTAGE
PAID
CINCINNATI, OH
PERMIT NO. 770

Copy/ADV Deadline for the May/June 2020 Legend is
June 17, 2020
Email: thelegend@lakeloreleiohio.com

LAKE LORELEI DAY at JOHN'S FLOWERS

Saturday, May 16

9 AM - 6 PM

On Howard Road, one mile south of Fayetteville,
just off Route 68

513-875-3400

*A percentage of the entire day's
sales will be donated to the
LL Women's Club.*

How YOU can participate:

- 🌸 Go to John's on **Saturday, May 16th** to purchase flowers and plants
 - 🌸 *Follow Ohio Social Distancing Guidelines*
- 🌸 Order by Phone on **Saturday, May 16th**
 - 🌸 *Pay by credit card and pick up or have it delivered the next week (\$20.00 delivery fee)*
- 🌸 Buy a Gift Certificate on **May 16** (by Phone & CC) and visit later to select your plants
- 🌸 Call ahead (10 days) for special orders and pick up on **Saturday, May 16th**

513-875-3400

