

# The Legend of Lorelei

Volume 50, Issue 4

July / August 2021



## Letter from the Editor

I would like to express my heartfelt appreciation to every person who has ever run for the **BOARD OF TRUSTEES**, or served on the Board. This is an almost thankless duty that requires hours of commitment and thought.

**In This Issue!**  
**Dredging**  
**Ballot Info**

While I may not always agree with the decisions made, I believe that any person who steps up for this position (and really any volunteer here at the lake), does so from his or her good intention. We all want what is best for this lake community. Let us respect each other, all ideas, and opinions on how to maintain and improve our wonderful neighborhood.

-M. Wallace

## Calendar

### July

8	Activities Committee Meeting	7:00 PM	Clubhouse/Pavilion
12	PRIDE Meeting	7:00 PM	Clubhouse/Pavilion
13	<b>GAME &amp; CARD Night</b>	<b>7:00 PM</b>	<b>Clubhouse</b>
17	<b>OUTDOOR EVENING CONCERT</b>	<b>7:00 PM</b>	<b>Pavilion</b>
20	Tuesday Fishing Tournament	6:00 PM	Marina

### August

3	Tuesday Fishing Tournament	6:00 PM	Marina
5	Women's Club Meeting	7:00 PM	Clubhouse/Pavilion
7	<b>POKER BOAT RUN!</b>	<b>6:30 PM</b>	<b>Marina/Pavilion</b>
9	PRIDE Meeting	7:00 PM	Clubhouse/Pavilion
10	<b>GAME &amp; CARD Night</b>	<b>7:00 PM</b>	<b>Clubhouse</b>
12	Activities Committee Meeting	7:00 PM	Clubhouse/Pavilion
17	Tuesday Fishing Tournament	6:00 PM	Marina
21	<b>NIGHT Fishing Tournament</b>	<b>Midnight</b>	<b>Marina</b>

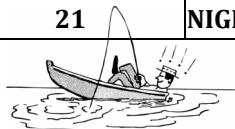

### September

2	Women's Club Dinner & Installation of Officers	6:00 PM	Clubhouse
7	Tuesday Fishing Tournament	6:00 PM	Marina
9	Activities Committee Meeting	7:00 PM	Clubhouse/Pavilion
13	PRIDE Meeting	7:00 PM	Clubhouse/Pavilion

**Next Issue Adv/Copy Due: August 18, 2021**

## **Board of Trustees - President's Report**

Rick Connors, President BOT

I am proud to have recently become the President of our Board of Trustees. It has been a very difficult last year for all of us personally and professionally. This was also the case for our lake community, which dealt with turnover in management staff, cancellations of normal meetings and functions, as well as the frustration of trying to find reliable, new employees.

I have lived at the lake for over twenty years and have served on numerous committees and clubs. I have learned a lot about different leadership styles both here as well as in my professional career over the years, and it makes me appreciate the time and dedication our prior leaders devoted to the lake.

The renewed passion and enthusiasm our lake members have shown (whether full-time or seasonal residents), has been amazing and just proves that everyone here sees the value in cohesiveness and working toward shared goals of making our lake a great community in which to belong.

My vision for Lake Lorelei is to bring all our energies, talents, and strengths together; continue to build on past successes, and then implement a strategic change to utilize all our resources to address our current & future challenges.

Some of the specific issues currently being addressed are:

- ◆ Modernizing our office server and technology abilities - It is important for all of us on the board as well as office staff to be able to conduct business online, collect dues, register boats, and accommodate our members.
- ◆ Website – We must have a website that is updated and maintained, to serve as a communication facilitator for members to obtain news, lake messages, and updates.
- ◆ Management structure – We are in the midst of developing a new leadership structure with an empowered Lake Director to manage the business and operational activities of the lake. This is a progressive change as we have hired a director who will live in our lake community and is one of us.
- ◆ Communication and Leadership of Committees – Clear, transparent, and consistent communication is a priority to me. Each trustee will be assigned responsibility for a committee as a liaison between the Lake Director & other board members. This will combine energies to also utilize volunteers as well as lake staff.
- ◆ Revenue – We need to be creative and challenge ourselves to develop more revenue. We will evaluate models to increase revenue going forward. The lake is a better value than ever before, and it is important that our revenues keep moving that value up.
- ◆ Dredging— Lake maintenance will always be an issue and a healthy, well-maintained lake is a common priority for everyone on our board, as well as our members. This is what drives the value of our properties. It is a key issue that we are all very aware of, and the goal is, after having dealt with some of the issues, that we will be better prepared to prioritize the needs and options to accomplish them.

We are all working extremely hard as a leadership team to develop a common vision for the benefit of all.

As your elected board, we encourage your participation and involvement:

- ◆ Please sign up and support our committees such as Pride, Water Quality, Activities, the Legend, and the Women's Club.
- ◆ Please attend board meetings and bring us ideas and additional resources to utilize and grow!

These objectives are a work in progress and will take time to develop and execute. We will be messaging further about all the exciting developments we are currently working on and plans for future projects.

I do ask that you be patient, and have respect for your BOT members, lake staff, committee members, as well as each other. Please understand that change takes time and allow us to prove that we are here for the improvement of our whole community. 🍷

**Contact the entire Board of Trustees  
with one email address:**

**board.trustees@lakeloreleiohio.com**



# Fisherman's Wharf

## At Lake Lorelei



**Owner/Operators  
Barb and Bob Kiley  
LLPOA Members since 1970**

Ohio Lottery and Instant Tickets

Bait ~ Ice ~ Beer ~ Gas

ATM



## Activities Committee - Upcoming Events

# FREE Concert at the Pavilion



**Saturday, July 17th  
7-11**

**Jordan Miller Band**



## Poker Boat Run!!

**Saturday August 7th; rain date August 14th**  
*Starts at the Marina at 6:30 pm*

**Dock Hosts Needed!**  
Contact Michele at  
[dickymo4@cinci.rr.com](mailto:dickymo4@cinci.rr.com)

## END of SUMMER Party!

Information to follow

*Look for more details on the front board and on Facebook*

Activities **NEEDS** You!  
Please join us the **2nd Thursday**  
every month at 7:00 PM  
We need new members  
with great **IDEAS!**



## LOW-Impact AEROBICS at the Clubhouse

Every Monday,  
Wednesday and Friday  
**9:30 am**



Custom Building and Remodeling  
Kitchens • Baths  
Decks • Room Additions  
[www.stirncontracting.com](http://www.stirncontracting.com)

## Your Lake Lorelei Neighborhood Contractor

Visit us at [facebook.com/stirncontracting](https://facebook.com/stirncontracting)



Specializing in kitchen and bath remodels, additions, decks and docks. Call us today for a quote on your next project!

**Eric Stirnkorb 513-646-3909**

**Rick Stirnkorb 513-497-3659**

**Visit our web page or Facebook page for a gallery of our work.**

## LLPOA Town Hall Meeting Minutes - June 12, 2021

This year's Spring Town Meeting's main focus was to present the Lakes Fund Ballot and to discuss the reasoning for the amount of the assessment and the need for such a fund. It was our first in person meeting for over a year due to Covid restrictions.

Jimmy Johnson opened the meeting as acting president and started with the pledge of allegiance followed by a moment of silence for members who have passed. He gave special thanks to Mike Hopkins and John Ipsaro for their past years of service to the LLPOA. He then introduced the two newly elected trustees, James Padgett and Bruce Simeone. The newly elected officers were announced as **RICK CONNORS**- President, **JIMMY JOHNSON**- Vice President, **TODD STEINBRINK**- Treasurer, and **DENIS BEHM**- Secretary.

At that time Jimmy turned the meeting over to Rick Connors. Rick thanked the board for giving him the opportunity to be president and said he was very excited about the future here at the lake. He informed the membership how it has been tough year with all the covid restrictions, along with the office staff turnover and asked for members to be patient. He then introduced our new Lakes Director **CHRIS KWIATKOWSKI**, who will be focusing not only on the day-to-day operations, but also collection of past dues, and improving communications between the Board, the Office and our members.

A member presented the idea of term limits for trustees, which will be further discussed.

Bruce Simeone and Todd Steinbrink then gave the Board's PowerPoint presentation on the details of the Lakes Fund Ballot to be sent out in July. A summary of this presentation is printed on page 17 in this issue of the Legend, or a request for a copy can be made to the office. &



Shaggy to Chic mobile pet grooming is a new, up-and-coming business servicing your area. With 13 years of experience, I am now bringing my business to you. We provide all the services you will ever need to get your dog or cat looking and smelling great! Save the time and money of taking your pet to the salon and let our business make your life easier by servicing your pet right in your driveway. Less stress on your furry friend and more convenience for you!

*Schedule Your  
Appointment Today!*

*Shaggy to Chic Mobile Pet Grooming*

**Tel: 513-286-3101 / Email: [ShaggytoChicPetGrooming@gmail.com](mailto:ShaggytoChicPetGrooming@gmail.com)**

# Lake Lorelei

**Lake properties have been selling  
for premium prices this past year.**

Buyers are constantly calling me but the inventory is extremely low.  
If you are thinking about selling please give me a call.

*Thank you for your continued support!*



**SOLD BEFORE LISTED**

1281 Elms Cove Dr



**YOUR  
HOUSE  
COULD  
BE NEXT**

Your Address

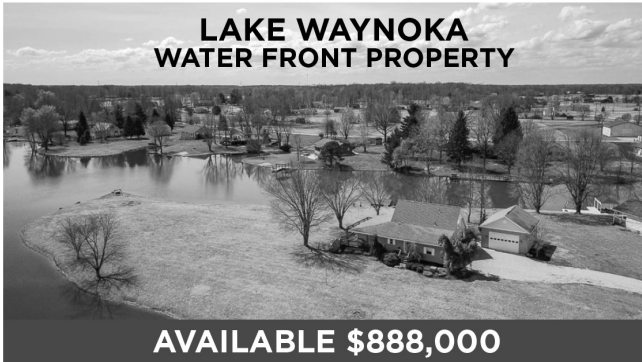

**LAKE WAYNOKA  
WATER FRONT PROPERTY**

**AVAILABLE \$888,000**

426 Waynoka Drive

— *Testimonials* —

*"It was a pleasure working with Marcia. She made the whole process go very smoothly and was extremely helpful. Without her timely action on our listing, I am sure we would have never been able to purchase our lovely home."*

— Erin



**FULL-TIME LAKE RESIDENT WITH OVER  
100 LAKE LORELEI TRANSACTIONS**

**Marcia Greenwald**  
AT HOME WITH DIVERSITY CERTIFICATION, SRS  
EXECUTIVE SALES VICE PRESIDENT

**(513) 503-1573**  
mgreenwald@sibcycline.com  
www.sibcycline.com/mgreenwald



This is not intended to be a form of solicitation if you are working with another broker.

# Fish Committee - Kids' Tournament

Tom Iles, Chair

The Kids' Fishing Tournament was held on June 5<sup>th</sup>: We had a great turn-out and some nice fish were caught. Winners were **JACE ILES**, **ASHER PURDEN**, and **ADDISON RUBINSTEIN**.



Addison Rubinstein, Jace Iles, Asher Purden (with Tom)



Sponsors were Miami Market (Herb Messer), The Legend of Lorelei, Lockjaw Lure Company (Justin Brandenburg and Philip Campbell), Debbie Russo, Pat Hines, Bill Mullins, and Dave Haskell.





INTEGRITY

EXPERIENCE

COMPETENCE

## **ROBERT L HETTINGER**

**Certified Public Accountant**

**Complete Tax Preparation  
IRS and State Tax Resolution**

**39 Years' Experience  
Local & Open Year-Round**

**The difference - a real CPA, and...  
Exceptional Personal Service**

***Why Trust Anyone Else?***

**120 S Apple Street**

(SR 68 between US 50 and the post office)

Fayetteville, Ohio  
**513-875-4395**

**roberthettingercpa@gmail.com**

**Member of The American Institute of Certified Public Accountants**

# Lake Safety Patrol - Boating Rules

Pete Zawaly, Coordinator

While enjoying the waters of Lake Lorelei, please be sure to follow all Lake Lorelei Boating Rules, some of which are listed, below:

## NEW PWC RULE AS OF DECEMBER 2020:

- **NO TOWING** by a PWC, at any time! PWC's are to be for RIDING ONLY!

## Speed Limits on the Lake:

- 35 MPH Sunrise to Sunset
- 6 MPH Sunset to Sunrise
- NO PWC operation after Sunset



## NO Wake - Idle Speed:

- Within 20 ft. of shorelines & docks
- Within 20 ft. of beaches & swimming areas
- Within 100 ft. of LSP boat while displaying flashing, oscillating, or rotating light(s)
- Within 150 ft. of marina ramp & gas pump
- During YELLOW flag conditions
- In ALL coves



## PROHIBITED Wake-Surfing:

- From 10am to 5pm on Saturdays, Sundays, & Holidays
- Behind I/O's & Outboards

## PROHIBITED Multi-Towing:

- From 10am to 5pm on Saturdays, Sundays, & Holidays
  - ◆ Includes skis, tubes, wakeboards & kneeboards

## Boat Operation:

- Counterclockwise (shoreline on right)
- Non-powered watercraft have the right-of-way

## NO SWIMMING:

- From LLPOA docks or shorelines
- From boats on main lake or outside of coves & inlets



## Boat Identification:

- Powered Watercraft:
  - ◆ 3" LLPOA Lot #'s displayed on the left & right of your boats, **stern**;
  - ◆ 2021 LLPOA Registration Decal displayed on the upper right **back corner**;
  - ◆ All ID's to be visible while on the water, a lift, or at a dock
- Non-Powered Watercraft:
  - ◆ 3" LLPOA Lot # & LLPOA Registration Decal on top, or visible above waterline

**Safety via Civility!**  
is our Lake Safety Patrol motto

# Fayetteville HOUSE OF WORSHIP

**We Invite You Sunday Mornings**  
**Adult & Children's Bible Study at 9 AM**  
**Worship Service at 10 AM**

*ALL CHILDREN INVITED!*

## **VACATION BIBLE SCHOOL**

**JULY 19TH - 23RD**  
**6 PM UNTIL 8 PM**

**AGE 4 THROUGH 5TH GRADE**

*PreRegister at the church July 19th at 5 PM*

**CALL 513-875-4055 FOR MORE INFO**



**500 Apple St.**  
**Fayetteville, Ohio 45118**

**513-875-4055**

**"Non-Denominational"**

## Lake Life

Lee Duncan

### What good are vultures?



Nearly all of us love the charismatic birds-of-prey we have here at the lake such as osprey, red-tailed hawks, and of course bald eagles. These beautiful and majestic birds are easy to love, but what about our most numerous raptor, **the vulture**?

We commonly see two species of vulture here at Lake Lorelei: the **black vulture** and the red-headed **turkey vulture** (with wingspans of five and six feet respectively).

In flight, the turkey vulture rarely beats its wings; it soars with an unsteady but graceful teetering motion with its wings in a shallow “V.” On the other hand, a black vulture will more often be seen beating its wings in a quick and snappy motion. When it soars, its wings are flat.

These two can frequently be seen together gathered around a tasty meal of dead fish or mammal, and both species serve a vital role in the lake’s ecology. By acting as nature’s “garbage disposers,” these scavengers help keep the ecosystem clean and free of infectious diseases. Amazingly, these birds have such corrosive stomach acid they can ingest meat contaminated with anthrax, botulinum toxin, cholera or rabies and not bat an eye. In fact, a vulture’s digestive system is so efficient at filtering contaminants that its poo (unlike human poo) is sterile—free of bacteria, viruses, or fungi.

Many people in Western societies look down on vultures as ugly and disgusting and fail to appreciate their importance. However, that sentiment doesn’t hold for every culture. On the Tibetan plateau, vultures are an essential component of any funeral. There, monks prepare the body and place it on a platform to attract the attention of vultures. After the birds have consumed the flesh, the person is considered to have been “buried in the sky.” In this way, the deceased loved one has performed one final good deed: offering something to another living creature before going off to rest in the sky.

I don’t imagine that funerary practice will gain much popularity here, but I hope the next time you see a group of vultures picking at a bloated, smelly, 40-pound carp that has washed up on the shore, you’ll have an appreciation of the service they’re doing for us all! ⚓

#### References:

<https://www.audubon.org/field-guide/bird/turkey-vulture>

<https://www.worldatlas.com/articles/what-is-the-role-of-vultures-in-the-ecosystem-and-wildlife-conservation.html>

<https://www.chattnaturecenter.org/visit/experience/wildlife/animal-facts/black-vulture/>



### Boating Season is Here!

See Water Safety Reminders around the Lake, or visit [www.lakeloreleiohio.com](http://www.lakeloreleiohio.com) for complete regulations.

Since being licensed as a REALTOR® in 1990,  
 I have gained the knowledge and compassion to help buyers and  
 sellers make the right home ownership and investment decisions.  
 As an owner of waterfront property since 2002, I have a strong  
 interest in the values and conditions of our community as well.  
 If I can assist you, please call me.



1095 LORELEI DR



1228 LORELEI DR



62 FLENSBURG DR



301 BREMEN DR



452 KLEIST DR

“Chris is the best REALTOR® we  
 had looking for a lake property.  
 She understood our requirement  
 & only showed us properties  
 meeting those requirements.  
 She is very detail oriented & the  
 process went very smoothly.”  
 Darlene & Bill - 2021

Life has Less Ripples  
 ... at the Lake!

boat waves...  
 lake days!

Chris Behm  
 Comey & Shepherd, REALTORS®  
 (513) 518-2353  
 e: [chrisbehm1@gmail.com](mailto:chrisbehm1@gmail.com)  
 w: [christinebehm.comey.com](http://christinebehm.comey.com)



## **PRIDE Committee Updates**

Jon Riehle, Chair

### **Hello Lake Family!**

We are very excited to let everyone know that the marina restrooms are almost done. The floors are in and look amazing! We are in the process of getting some wall art inside and a sign pointing to the restrooms to be placed in the grass between the cut through and the restrooms (pending approval).

To all you kayakers out there: We are waiting to get approval to install a kayak launch. This will be a rock launch with a handrail. We have a spot picked out, and once begun we will let everyone know where it will be located. We will be making a big deal about this so we can get a lot of you out to volunteer for a few hours and can get it completed in hopefully a day.

We have had several inquiries about mailboxes. To ensure that we can tackle some of the other projects around the lake, we are holding off on mailboxes until the fall. At that point I will post on all the LL FB pages that we are taking orders again. We would like to thank everyone who is supporting us with the purchase of these mailboxes.

We were planning a B&B Day at the lake. With everything else going on and the time it takes to plan this event, we have made the decision to hold off until next year. This winter we will put the plan and scheduling in place so we can have a huge turnout and make a major impact on areas of concern next fall.

I believe that is it for now. On behalf of myself and all the PRIDE Directors we thank you for your continued support and look forward to your volunteer hours to keep our fantastic lake community looking awesome! 🍷

## **LEE'S TREES**

**Certified Arborist**

**Pruning and Removals**

**Certification: OH-5277A**

**(513) 382-4575**

**treeman780@gmail.com**

# Women's Club Report

Jane Wyman, President

We were able to meet in the Clubhouse for our June meeting. We welcomed two new members!

Items that were discussed:

- ❖ The flower sale at LLPOA day at John's flowers earned \$1150 for the Women's Club.
- ❖ Donated \$100 to Fayetteville Fire Department and \$300 to Hope Emergency
- ❖ Barbecue/coleslaw cookoff has been postponed until February or March due to the other activities scheduled for this summer.
- ❖ Two **Game Nights** are planned for July 13<sup>th</sup> and August 10<sup>th</sup> at 7:00 pm in the clubhouse. Cards and games are on the agenda. The WC will provide non-alcoholic beverages and snacks. Please join us for a fun evening!
- ❖ The **Fall Yard Sale** will be the first weekend in October. Included in this event will be a personal care item drive for Hope Emergency, a white elephant sale, and a bake sale.
- ❖ **Chili Cookoff & Auction** on November 6<sup>th</sup> - bring your best chili to share and maybe you'll be crowned the winner!
- ❖ **Christmas Party** for the lake community on December 4 - bring your favorite covered dish to share, the meat, drinks and dessert will be provided. Christmas program and carols are a part of the evening entertainment. We hope to see you there.

We welcome new members to come to our next meeting on July 1<sup>st</sup> and see what we are all about.

Hope to see you soon,

*Jane E. Wyman*

## Tom Kuebler Carpet & Upholstery Cleaning 25 years experience



**Deep Steaming  
Truck-mounted equipment**

**Living room & Dining room & Hall \$45  
Any Five areas \$75  
Sofas \$45 · Loveseat \$35 · Chair \$25**



**Now offering carpet and upholstery cleaning for  
RV's · Motor Homes · Campers · Car Interiors**

**Call 513-444-4146**

**"I clean each carpet like it is my own"**

**All work guaranteed**



**The Lawn Care and Landscaping Professionals**  
Residential and Commercial properties

***Total Lawn Maintenance ~ New Lawns/Repairs  
Full Service Landscaping  
Hardscapes/Retaining Walls  
Outdoor Paver Patios/Walkways ~ Water Features  
Stone Works ~ Shore Repair ~ Beaches  
Seasonal Lawn/Bed Maintenance  
Fence Install-Vinyl/Split-Rail***

Competitive Rates ~ Fully Insured ~ Free Estimates

Call **Josh** to schedule your free estimate **today!**

**(513) 305-5296**

Visit Us Online **[www.walkerlandscapeandlawncare.com](http://www.walkerlandscapeandlawncare.com)**

Or email **[WLLC@twc.com](mailto:WLLC@twc.com)**

***Mention you found us in The Legend of Lorelei for \$\$ OFF Savings for New Customers***



## Lakes Fund Presentation – LLPOA Town Hall Meeting, June 12, 2021

*The following is the PowerPoint presentation created and presented by Bruce Simeone and Todd Steinbrink.*

### BELIEFS USED TO MAKE THIS DREDGING PROPOSAL

- ◆ We all have a responsibility to the Community, no matter where we live.
- ◆ We are here because the water is here.
- ◆ Everybody is equal and nobody is special.
- ◆ Not everything in the community is perfect.
- ◆ Just because we struggle with some things, do not let everything else suffer.
- ◆ We have a responsibility to each other and the Lake/Water.
- ◆ The Lake is man-made. Man-made items require maintenance.
- ◆ Tell the truth, plan by recognizing the truth and do your best to live up to the plan.
- ◆ Let the past be the past, but learn from it or make the same mistakes again.
- ◆ Forge a new future to make that future better than the past.

### BOTTOM LINE

***If we are together, Nothing is impossible. If we are divided, ALL will fail.***

### HISTORY OF DREDGING

- ◆ The last Partial dredging effort was completed in 1991 (*only 23 years after the lake was first filled*)
  - ◇ *Belief – We have a responsibility to the Lake / Water*
- ◆ 30 years later, lake-bottom build-up remains an issue that should have been addressed then for a more permanent, ongoing resolution.
  - ◇ *Belief – Learn from the past*
  - ◇ *Belief – The lake is man-made. Man-made items require maintenance.*
- ◆ Several efforts to pass an assessment over the past 5 years have failed for numerous reasons.
  - ◇ *Belief - Let the past be the past. Learn from it.*
- ◆ A committee was formed in 2018 to provide greater understanding of the scope of the problem, the costs and recommendations for resolving our current issues and addressing it proactively for the future.
  - ◇ *Belief - Forge a new future and make that future better than the past.*
- ◆ In 2018 and 2019, significant education was provided to the membership regarding the several methods, costs and ongoing efforts necessary for a successful project.
  - ◇ *Belief - Everybody is equal, nobody is special.*
- ◆ The facts haven't changed, and these issues will continue to compound until addressed. Meanwhile, the bottom continues to fill, green and harmful blue algae growth is more common, the e-coli risk is greater and eventually these will harm the existing fish population and everyone's enjoyment of the lake.
  - ◇ *Belief - Let the past be a past but learn from it.*
- ◆ The Dredging Committee's work has continued, including ongoing research on the most effective dredging method(s), order of operation and funding in preparation for the project.
  - ◇ *Belief - Tell the truth, plan by recognizing that truth, and do your best to live up to that plan.*

*Continued on page 18*

Continued from page 17

## THE PLAN: EXECUTIVE SUMMARY

In response to the continued desire of the membership, the Board is proposing an assessment designed to “turn on the spigot” for the benefit of funding ongoing maintenance and enhancements to our lakes.

- ◇ *Belief - We have responsibility to each other and the lake.*
- ◇ *Belief - Let the past be the past, learn from it or make the same mistakes again.*

The current (February 1994) annual dues and subsequent service fees are only marginally enough to maintain current non-water related operations, much less take on any major projects such as dredging or improving the existing water features of our lakes.

- ◇ *Belief - Not everything in the Community is perfect.*

Without passing a measure to provide additional funding, the lake bottom and water issues won't get better.

- ◇ *Belief - Forge a new future to make that future better than the past.*
- ◇ *Belief - The Lake is man-made. Man-made items require maintenance.*

**If the community wishes** to have dredging and other enhancements completed sooner than the next 10-14 years, the ballot language allows the LLPOA to pledge the approved assessment to borrow the funds necessary to complete dredging **AND** additional projects over the next 3-5 years.

- ◇ *Belief - Forge a new future to make that future better than the past.*

A dedicated committee (of no less than 7 members) will control the planning, execution and oversight of the comprehensive enhancement plan.

- ◇ *Belief - Tell the truth, plan by recognizing the truth, and do your best to live up to that plan*

The full Board would like the community's support in passing the assessment to create a **Lakes Fund** and form an independent committee to implement a lake enhancement program.

- ◇ *Belief - Forge a new future to make that future better than the past*

## THE BALLOT

The Ballot creates a new dedicated assessment - the **Lakes Fund**.

Much like the Roads Fund, the **Lakes Fund** is designed specifically and exclusively for lake-water related projects. Eligible uses of the **Lakes Fund** include:

- ◆ Dredging
- ◆ Shoreline
- ◆ Beach
- ◆ Spillway
- ◆ Water quality
- ◆ Valves

It asks for an annual assessment of **\$300 per membership**.

It would further amend the governing document to allow the pledging of the **Lakes Fund** assessment to borrow funds for earlier commencement of the projects.

**PROPOSED FUNDING**

**TIMING:**

The Ballot would create a **Lakes Fund** and allow the LLPOA to begin collection of funds beginning with this fall's billing cycle.

**THE MATH:**

On an annual basis, collecting **\$300** from the members will create a cash flow of approximately **\$207,000** per year.

**FINANCIAL:**

An annual cash flow of that amount would enable the Fund to borrow up to \$2MM up-front.

**RECOMMENDATION TO THE BOT:**

The Dredging Committee has recommended a 3-4 year project plan that would spread out the expense, drawing borrowed funds only as needed, accumulating assessment funds to limit borrowing and reducing interest expense.

**ELIGIBILITY:**

Additional eligible projects will only be considered 5 years after the assessment begins.

**BY THE NUMBERS**

If we used the Lakes Fund annual assessment **only as it is collected**, the work would take 13 years to complete the desired projects.

	<b>Assessment Collection</b>	<b>Cumulative Balance (end of year)</b>	<b>Project Timeline Without Borrowing</b>
Year 1	207,000	207,000	
Year 2	207,000	414,000	
Year 3	207,000	621,000	
Year 4	207,000	828,000	
Year 5	207,000	1,035,000	North Inlet - \$1,000,00
Year 6	207,000	242,000	
Year 7	207,000	449,000	
Year 8	207,000	656,000	
Year 9	207,000	863,000	Coves -\$ 800,000
Year 10	207,000	270,000	
Year 11	207,000	477,000	
Year 12	207,000	684,000	Capture Lakes - \$650,000
Year 13	207,000	241,000	Beaches, Shoreline, etc.

Continued from page 19

**A CURRENT AND ON-GOING SOLUTION  
(Initial draft thought-process WITH a loan)**

	Assessment Collection	Project Timeline	Cumulative Funds Available (begin of year)	Borrowed Amounts	Req'd Assoc Pmt (annual) Tr-1	Req'd Assoc Pmt (annual) Tr-2	Req'd Assoc Pmt (annual) Tr-3	Total Annual Payment
Year 1	207,000							
Year 2	207,000	North Inlet - \$900,000	207,000 + 693,000 (L -1) = 900,000	693,000 (Tr-1)	84,000			84,000
Year 3	207,000	Coves - \$750,000	207,000 - 84,000 = 123,000 + 627,000 (L-2) = \$750,000	627,000 (Tr-2)	84,000	75,000		159,000
Year 4	207,000		207,000-159,000 = 48,000		84,000	75,000		159,000
Year 5	207,000	Lakes - \$600,000	48,000 + 207,000 = 255,000 + 345,000 (L-3)	345,000 (Tr-3)	84,000	75,000	41,000	200,000
Year 6	207,000		7,000		84,000	75,000	41,000	200,000
Year 7	207,000	Supplemental projects recommended by committee	14,000		84,000	75,000	41,000	200,000
Year 8	207,000		21,000		84,000	75,000	41,000	200,000
Year 9	207,000		28,000		84,000	75,000	41,000	200,000
Year 10	207,000		35,000		84,000	75,000	41,000	200,000
Year 11	207,000		42,000		84,000	75,000	41,000	200,000
Year 12	207,000		133,000			75,000	41,000	116,000
Year 13	207,000		299,000				41,000	41,000
Year 14	207,000		465,000				41,000	41,000
Year 15	207,000		631,000				41,000	41,000
Year 16	207,000		838,000					
Year 17	207,000		1,045,000					
Year 18	207,000	North Inlet	1,252,000					

The ability to use the annual assessment cash flow would enable the ability to borrow the funds, in stages to pull the work forward to complete sooner, at less cost (inflation and less silt to be removed), paying off the loans over a 10-14 year period and create additional funds for supplemental projects **AND** provide a permanent funding base for revisiting the dredging needs in the future. Effectively setting up for a dredging cycle every 20 years.

**The PROJECT TEAM**

The **Lakes Fund**, similar to the Roads Fund, would be overseen by an independent committee outside of the Board of Trustees.

The team would consist of dedicated members of the community (to include a chosen team leader and likely members from the Dredging Committee formed in 2018) to finalize planning of methods and timing based upon the significant knowledge gained through the Dredging Committees research over the past 3 years.

- ◆ If the task, once planned in detail by the Committee becomes too involved, a potential Project Manager may be required.

The project team will be responsible for:

- ◆ Creating and managing the RFP (Request For Proposal) process
- ◆ Creating and communicating a Master Plan, much like the bridge work
- ◆ Coordinating vendor selection
- ◆ Overseeing the budget and completion of all work associated with the project

One member of the Board will be involved with the team as a liaison for the Board and to facilitate, review, and oversee acceptance and payment of all expenses.

The project team will be accountable for:

- ◆ On-going, semi-annual communication to the Community and the BOT
- ◆ Total clarity of the movement of funds
- ◆ Executing the Master Plan, including the timing of that plan, submitted to the BOT

**GLLWIC**  
**(Greater Lake Lorelei Water Improvement Corporation)**

They are designated as a 501(c)3 Charitable Organization.

The mission of GLLWIC is to *improve the quality of the water that flows into, through, and out of Lake Lorelei*

- ◆ By Funding effective soil and water conservation projects with grants, community partnerships, tax deductible donations and bequests.

The Commitment from GLLWIC is:

- To design and promote a comprehensive fundraising strategy including private donations and grants in cooperation with the LLPOA Trustees.
- GLLWIC will hold funds raised in a designated “Dredging Fund” to be dispersed through a 50/50 matching grant as funds are available.
- Funds will be provided to LLPOA through the GLLWIC project funding guidelines.

Once the Lake has committed to a specific dredging plan, GLLWIC is dedicated to pursuing a targeted capital funding campaign.

For more information about GLLWIC please Contact Cindi Wetzel.

**ADDITIONAL INFORMATION**

Some members have expressed interest in “pre-paying” their assessment, in order to provide increased funds up-front to reduce borrowing costs. If they do “pre-pay”, NO DISCOUNT to the amount due will be provided.

This “good-faith, pre-pay” effort is welcomed by the Board. ⚓

***From LLPOA Governing Documents:***

*Town Meetings of the members of the Association will be held at the Lake Lorelei Clubhouse twice during each calendar year, once in the spring and once in the fall, on such dates as shall be designated from time to time by the Board of Trustees. The purpose of these meetings is for the discussion of matters of local government by a General Assembly of the Members in Good Standing, and to give the opportunity to express opinions and ask questions. Such meetings will not be related to any other regularly scheduled or special meetings.*



**LOOK ALIVE!  
DRIVE 25**

**Watch out for  
Walkers, Bikers, &  
Golf Carts**

# Fish Committee - Upcoming Events

## 2021 Tournament Schedule & Rules

**Night Tournament - August 21st; 12am - 8am**  
**Fall Tournament - October 16th; 7:30am -3:30pm**

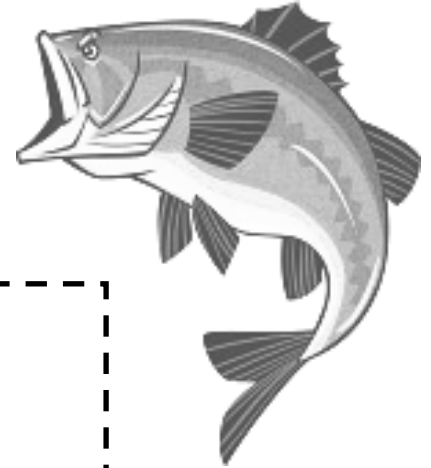

### Entry

Entry Fee: \$20.00 Per Team  
Individual Fee: \$15.00  
\$5.00 Of Entry Will Go Toward Big Bass

### Prizes (number of boats competing)

5 Boats Or Less: 1st Place 100%  
6-8 Boats 2 Places: 70% & 30%  
9 Boats And Up 3 Places: 50%-30%-20%

### Tuesdays

July 20th 6-9:30 P.M.  
Aug. 3rd 6-9:30 P.M.  
Aug. 17th 6-9 P.M.  
Sept. 7th 6-9 P.M.  
Sept. 21st 6-8:30 P.M.

### Tuesday Evening Rules

- ◆ Ties Will Be Resolved In The Following Order:
  - ◇ Largest Number Of Fish, Largest Fish And A Flip Of A Coin
- ◆ A Limit Of 5 Bass Per Person At Least 12 Inches Long, Measured With The Mouth Fully Closed
  - ◇ 10 Bass Per Boat
- ◆ Official Time Will Be Kept. One Person Must Be At The Marina And On The Ground At Official Quitting Time.
- ◆ All Fish must be brought to the scales in a weigh-in bag with sufficient water.
- ◆ All Boats Must Return To The Check-In Site For The Weigh-In.
  - ◇ Teams Or Individuals That Are Late For The Weigh-In Will Be Penalized 1 Pound Per Minute Up To Ten Minutes, Then Disqualified.
- ◆ No Dead Fish Will Be Weighed In.
- ◆ All Property Owners Must Have **2021-22** Stickers On Their Boats.
- ◆ We Understand And Agree That The Lake Lorelei Property Owners Association, Inc., Its Members, Trustees, And Other Participants Are Hereby Waived Of Any Responsibility For Damages, Injury, Or Loss Incurred During This Tournament.
- ◆ No Live Bait Is Allowed.
- ◆ **Be At The Marina at 5:30!!!**

### Angler Of The Year Point System

- ◆ Points Will Be Awarded To Individuals for each night of fishing.
- ◆ The End Of The Year Prize Will Be \$100.00 (One Hundred Dollars) Cash And Two Plaques. Paid For By The Fish Committee.
- ◆ Points Will Awarded As Follows:
  - ◇ 5 Points First Place,
  - ◇ 4 Points Second Place,
  - ◇ 3 Points Third Place,
  - ◇ 2 Points For Big Bass. Big Bass Will Be Awarded To Both Individuals No Matter Who Caught The Fish.
  - ◇ 1 Point Will Be Given For Showing Up If You Do Not Place.



# BINGO

<b>BINGO</b>				
15	20	38	58	77
4	32	50	63	80
8	19		71	79
11	35	43	55	73
9	22	41	66	70

EVERY WEDNESDAY

ST. ANGELA MERICI PARISH HALL

130 STONE ALLEY, FAYETTEVILLE

(INFORMATION CALL 8:00 AM TO 4:00 PM (513) 875-5020)

DOORS OPEN AT 5:30 PM GAMES START AT 7:00 PM OVER AROUND 9:30 PM

18 REGULAR GAMES

FINAL GAME: JACKPOT COVERALL \$1,000. IF WON IN 45 NUMBERS OR LESS

3 EXTRA GAMES, A QUICKIE COVERALL, TRIANGLE, STARBURST

BIRTHDAY SPECIAL: WEEK OF BIRTHDAY RECEIVE FREE TRIANGLE & STARBURST SHEET

PULL TABS: KING OF THE MOUNTAIN TOP PRIZE \$599.00

CRANK IT UP PROGRESSIVE: AS OF JUNE 16, at \$2,000.00

FLASH SEALS, JOE'S, MANY OTHERS

FOOD & REFRESHMENTS: TERRY'S PIZZA, DESSERTS, Etc.

Need a hand?  
Call *The Man!*



Carver Properties  
Lawncare &  
Property Maintenance

Doug Myers  
For help from the  
Handyman, call:

(513)673-7831



CONTACT Ernie Reese 24/7!

937-661-4142

513-276-0176

Email: [ernie@reese机械heatingandcoolingservice.com](mailto:ernie@reese机械heatingandcoolingservice.com)

Web: [www.reese机械heatingandcoolingservice.com](http://www.reese机械heatingandcoolingservice.com)

LIKE us on FACEBOOK: REESEMECHANICAL

- We offer FREE estimates
- We NEVER charge overtime
- We BELIEVE in prompt and high quality work

Sales Service Installation

Receive a FREE Condenser & Indoor Coil Cleaning  
When you make an appointment for a \$65 Service Check

\$80 Value

Have your Cooling System  
cleaned for Summer!

Contact Ernie Reese 24/7  
(937) 661-4142 or (513) 276-0176  
Like us on Facebook

Additional charges apply to oil furnaces. Other restrictions may apply. Call for Details. Not valid with other offers. Can only be redeemed by Ernie Reese of Reese Mechanical. Offer must be mentioned and redeemed when service check appt. is made. Make appointment by contacting Reese Mechanical.

## Community Corner



**BRIANNA PLAPP** and **TAYLOR SMUCKER** were married at a beautiful Lakeside ceremony on June 5, 2021. The wedding and reception were held at the home of Bree's parents, Amy & Rodney Plapp. Taylor's parents are Tina & Craig Smucker. The happy couple honeymooned on Captiva Island.

Congratulations Bree & Taylor!

**Megan Connors** graduated from Fayetteville-Perry High School this spring. She will be pursuing an education in Dental Hygiene in Cincinnati.

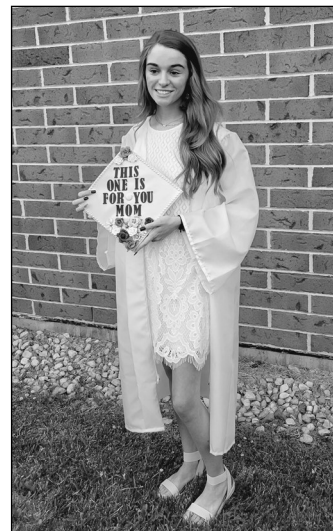

This year's Lake Committee Scholarship went to Lake resident **OLIVIA COLE**. She will be attending Northern Kentucky University, majoring in Psychology. The Legend of Lorelei provided the funds to the Fayetteville-Perry School Scholarship Program.

On April 17th, **LARKIN DEAN** traveled to Columbus to compete in the Ohio State Amerifest Pageant. Larkin brought the title of Ohio State Little Miss home to Lake Lorelei. She is very excited to use this new state title to bring awareness to ways anyone can help bring assistance and joy in their local neighborhoods. Next she plans to represent Ohio at the National Amerifest Pageant in Nashville, Tennessee on the weekend of July 10th.

Larkin also competed in the Ohio State America's Amateur Model and Talent of the Year. Larkin was crowned as the 2021 Ohio State Model of the Year in the 3-7 year old age bracket.





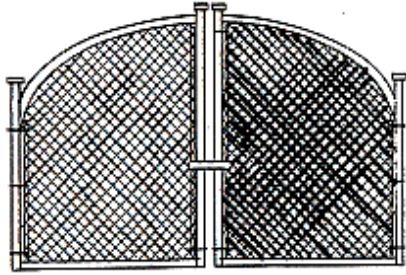

## COUCH'S FENCE COMPANY

**INDUSTRIAL—RESIDENTIAL  
ALL TYPES OF WOOD & CHAIN  
LINK**

**TERRY COUCH  
(513) 625-7771  
(513) 625-0371 FAX**

**5414 ST. RT. 133  
WILLIAMSBURG  
OH 45126**

## Only One Offer?

***That's NOT ENOUGH!***

Before committing to another agent or trying to sell on your own, call me and we will discuss how to maximize your profit by attracting multiple offers.



**Jenny Fehr REALTOR®**

*Lake Resident*

[jfehr@cinci.rr.com](mailto:jfehr@cinci.rr.com)

**513-314-1391**

**BASTION  
REALTORS®**  
*move.build.invest*



# New Life

A place for great beginnings

41 N DUNHAM AVE, FAYETTEVILLE

(IN THE SKYLINE PLAZA)

SUNDAY MORNINGS - 10 AM SUNDAY SCHOOL

- 10:45 AM WORSHIP SERVICE

A FUN, JOY-FILLED PLACE TO SPEND SUNDAY MORNING



Find us on Facebook at <https://www.facebook.com/groups/nlcfayetteville>

## The Legend Looks Back

1971

### May/June

- Trustees elected to the Board this year were Kenneth Morse, Arnold Hurley and Robert Eckstein.
- LLPOA offered Lot mowing for \$6.00 - \$8.00, or \$30.00 for the season.
- Three lawsuits with seven pieces of litigation were ongoing with American Realty.
- There were strained relations due to various promises made when selling lots unfulfilled. The main lawsuit was over AR defaulting on the Clubhouse mortgage.
- The HOT BUTTON issue of the day was...payment of dues...and there was mention of the coves starting to fill in with silt...
- The menu for the Lake Restaurant included:
  - 2 eggs, ham, toast and coffee for \$1.40
  - Porterhouse steak dinner for \$3.00
  - Ham and Cheese Sandwich for \$.75
  - Milkshake for \$.40

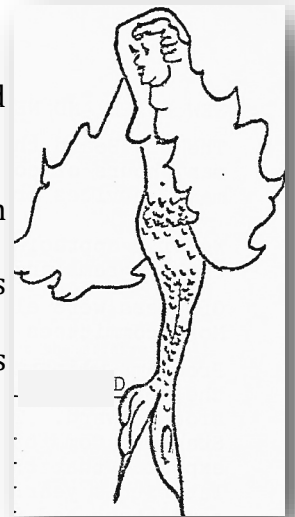

### July/August

- The Annual Charge for each lot owner was \$48.00. There was a controversy concerning the fee and if it pertained to each member or each lot. Judge John H. Huston ruled that the covenants were written to define charges as 'per each member'.
- The Summer-long Fishing Derby was well under way. The largest catches so far were a 4 lb.-6 oz. bass, a 7 lb. catfish, and a 1 lb.-5 oz. crappie.
- The Entertainment Committee's plans for August and September included a Luau on the main beach, Bingo, a Monte Carlo night. A 50-50 Dance (half country and half ballroom), and monthly potluck dinners.
- 2,026 cars and boats were checked through the security gate over the July 4<sup>th</sup> weekend (Friday, Saturday, Sunday).



1981

### May/June

- Trustees elected were Ed Fuhrman, James Hicks and Tom Kitchen.
- As of this year, there were 1,230 property owner members, with 316 homes having been built.
- LLPOA recovered \$13,000 from American Realty's bankruptcy proceedings and was in the process of suing the lawyer who represented the lake in 1972.
- American Realty defaulted on the mortgage.
- The issue of the day was trash on the roads...

*Continued on page 28*

# M & M Tree Service and Landscaping

**Free Estimates  
60 Ft. Bucket Truck**



### Services

- Tree Removal
- Stump Removal
- Dead Wooding
- Tree Cabling
- Pruning
- Landscaping
- Mulching
- Yard Clean up
- Bobcat Service

**513-432-5227**

# All About You

## Hair Salon & Day Spa, LLC.

**Tue 3pm-8pm ~ Wed-Fri 9am-8pm  
Sat 9am-3pm**

**At the intersection of US-50 and SR-131  
19426 Vera Cruz Road  
Fayetteville, OH 45118**

**513-875-3000**

*Full Service Salon*

**Let the Fireworks Begin  
Get that NEW LOOK!**

*~Now Hiring~*



**Amann Brothers  
Construction  
Fayetteville, Ohio**

**513-875-8033  
513-490-3675**

[amannbros@gmail.com](mailto:amannbros@gmail.com)



- Concrete
- Driveways
- Sidewalks
- Porches
- Patios
- Boat Ramps
- Footers
- Garage Floors
- Basement Floors
- Concrete Removal
- Concrete Drilling
- Concrete Sawing
- Block Retaining Wall
- Brick Pavers

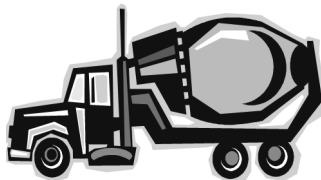

**Mark Amann**

- Bobcat Work
- Gravel Driveways
- Fill Dirt
- Top Soil
- Sod & Seeding
- Landscape
- Fencing of any kind
- Boat Docks
- Rip Rap

Also Available:  
Garage Kits  
Pole Barn Kits  
&  
MORE



## STEPHANIE ZURMEHL FOR SCHOOL BOARD

I am running for school board in the November 2nd 2021 election, and I would be honored to serve on the Board of Education for Fayetteville-Perry Local Schools

I am a Conservative, Christian wife and Mom with three kids; ages 2, 6 & 15. My husband and I live on a farm in Fayetteville School District. I began attending the school board meetings last year to voice my own concerns along with other parents' concerns and praises when they couldn't attend. Since then, I have the desire to serve our kids, our community and our school.

Our kids are our future and they deserve the best education. The Ohio Department of Education has been failing our kids. I want to work side by side with our school, the parents and staff: To align our curriculum back to the basics; To give our teachers the tools they need to help our kids succeed; To stand up for our kids when no one else will, while making sure they don't become victims of tyranny from the government and their funding.

It'd be my privilege to fight for your kids and their education.

Continued from page 26

July/August

- A new dues increase vote was planned to increase the annual fee from \$98.00 to \$150.00. The rationale appeared to be for implementing a sewer system and to maintain the roads (all gravel).
- Interest rates on delinquent accounts were increased from 8% to 18% annually (now, that is inflation!).
- The Lake Safety Patrol reported the “Safest Summer Ever!”



1991

May/June

- Trustees elected were James Hill, Lee Agee and Harry Scott.
- **150** members and their families participated in this year’s Beautification & Barbecue weekend... Amazing!
- Women’s Club held a flower and plant sale.
- Revisions to Articles III and IV of the Lake Code were published in the issue. Those articles were about member meetings and elections processes.

July/August

- Dredging began in May of 1991, with the passage of a dedicated and limited assessment vote. The first activity planned was the creation of retention ponds.
- The outside of the Clubhouse was painted by volunteers and the Women’s Club donated funds for a new carpet and floor covering. The outgoing President was Kay Haggis.
- Thursday night Bridge was just starting up.
- Activities Committee’s planned events were Softball, an August Pot Luck and a September Pig Roast.

2001

May/June

- Trustees winning the election were Joe Graham, Kathryn Greene, and Taylor Frazier.
- **Only 70** members and families worked at the B&B weekend. The outside of the Clubhouse was painted...WOW.
- Members in Bad Standing were less than 10% of the total.
- A public restroom at the Marina was approved by the Board.

July/August

- There was a “monster” rainstorm the night of July 17<sup>th</sup>, with both boats and docks being washed down-lake. A part of the spillway bank was washed away and many homes were. Rain gauges measured 5”, 7” and 11.75” at different locations.
- 1991 was the first year that lake water was tested.
- The Activities Committee took over running the Clubhouse restaurant as a pub with limited menu items. It was called the “Drop Anchor Lounge”.
- The Teen Activity Club planned a “Back-to-School” Dance for August 24<sup>th</sup>.

Continued on page 30

## D & M Services



Weekly, Bi-Weekly, Monthly  
Or One Time Service  
Thorough Cleaning Service  
**FREE ESTIMATES!**  
(513) 265-4223  
dickymo4@cinci.rr.com

**Dick & Michele Hatton**  
Lake Residents

# CAPLINGER

sales and service

Lawn, Garden, Farm & Motor Sports

**664 W Main St., Blanchester, OH 45107**

**Phone: 937-783-8330**

Monday-Friday; 9 am to 5 pm

Saturday; 9 am to 12 pm

*Selling the area's largest selection of parts, accessories  
and equipment for:*

- |                 |             |              |
|-----------------|-------------|--------------|
| *STIHL          | *BRANSON    | *KOHLER      |
| *ARIENS/GRAVELY | *VORTEXX    | *HONDA       |
| *TORO           | *GENERAC    | *TECUMSEH    |
| *SCAG           | *HAMMERHEAD | *GRASSHOPPER |
| *DR POWER       | GO-KARTS    | *TRAEGER     |
| *HUSQVARNA      | *KAWASKI    | *BCS AMERICA |
|                 | *BRIGGS     |              |

*Parts & service available for most other makes & models  
of lawn & garden equipment*

**Financing Available / Pick up & Delivery Available**

[www.caplingersalesandservice.com](http://www.caplingersalesandservice.com)

EMAIL: [caplingersales@gmail.com](mailto:caplingersales@gmail.com)

***Short time -2020 Prices!***

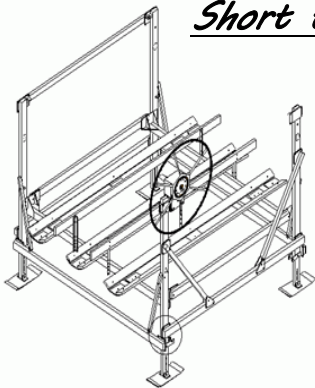

**>LOWEST PRICES**

**>HIGHEST QUALITY**

**Ohio Boat Lift, LLC**

Dealer for Lakeside Lift Corp.

Pete Zawaly, Lake Lorelei

Call: 614-216-1798

Email: [peter@ohioboatlift.com](mailto:peter@ohioboatlift.com)

Visit: [www.lakesidelift.com](http://www.lakesidelift.com)



[www.hudepohlheatandair.com](http://www.hudepohlheatandair.com)

**(937) 446-4200**

Email: [hudyhvac@gmail.com](mailto:hudyhvac@gmail.com)

24 Hour  
Emergency  
Service



State  
License  
# 31213

*"A Professional is Not Satisfied Until You Are"*

***Geothermal Specialist***

***Sales • Service • Equipment • Replacement***

**SERVICES**

- Heating
- Venting
- Air Conditioning
- *Geothermal Specialist*
- Heat Pumps
- Oil
- Gas

**PARTS & ACCESSORIES**

- Programmable Thermostats
- Humidifier
- High Efficiency Air Cleaners

***Commercial • Residential***



*Sea Ray*  
CINCINNATI



**All New 2022 20' Moomba Mondo**

*Sea Ray* BAYLINER *South Bay*  
SO WORTH IT!

HARRIS **MOOMBA**  
TOURNAMENT INBOARD BOATS



**4811 Kellogg Avenue Cincinnati, OH 45226**  
**513-871-5555 [www.searayofcincinnati.com](http://www.searayofcincinnati.com)**

Continued from page 28

**2011**

May/June

- Candidates for Trustee this year were Jimmy Johnson, Dan VanDiver, and Jane Wyman.
- The Election Schedule was later than earlier years, with the Spring Town Hall to be held on June 18th.
- ODNR approved a program to reduce the Canadian Goose population by shaking eggs.
- Women's Club held their Second Fashion Show and Luncheon.
- PRIDE sold Topsoil as a fundraiser.



July/August

- Jimmy Johnson, Dan VanDiver, and Jane Wyman were elected to serve again on the Board of Trustees...big surprise!
- The Electronic Gate System was installed and expected to be fully functional in August.
- The Women's Club hosted a luncheon, boat ride and Bingo for the Lake Waynoka Squaws.
- Tom Iles was busy running the various Fishing Tournaments (and still is!). ♪

**JJ Lift Service, LLC.**



Sales & Service for  
all Hewitt Lifts

Sales Rep for **Hewitt Boat Lifts**  
and Accessories

[www.hewitt-roll-a-dock.com](http://www.hewitt-roll-a-dock.com)

**Jimmy Johnson**

[jimmyjohnson@cinci.rr.com](mailto:jimmyjohnson@cinci.rr.com)

**513-875-3715**

Dawg Daze



[www.dawgdazecbdtreats.com](http://www.dawgdazecbdtreats.com)

**CBD Treats**  
dawgdazecbdtreats@gmail.com

All Natural  
Organic Dog  
Treats



**RJC**

**FLOORING & CONSTRUCTION**

Hardwood Installation, Refinishing, Tile, Laminate  
& General Construction

**(513) 233-5581**

1685 Lorelei Dr.  
Fayetteville, Ohio 45118

Jared Clem  
Owner

[RJCFlooring@gmail.com](mailto:RJCFlooring@gmail.com)

Free Estimates

# Lakeside Gardening

Gary Hetzell

As we approach July and August, this is a great time to divide and transplant Iris, Peonies, Daylilies, summer Phlox and other perennials that have finished blooming.

Always remember this rule of thumb for pruning flowering plants and shrubs: pruning should be done after flowering is complete - don't wait till fall or next spring or you will be cutting off next year's flowers.

During most of these two months gardeners are enjoying picking veggies and looking at all their flowers which should be at their peak.

There are several methods for preserving your produce to enjoy well into the winter months, first the old reliable canning method which we don't do much of anymore since it is more time consuming than our preferred method of freezing (you can use a food saver vacuum seal machine). Both methods keep produce fresh for very long periods.



Gary's Garden

Lastly you want to stop fertilizing all roses, shrubs and plants by the end of August to avoid promoting new tender growth that might be damaged over winter. Enjoy your summer yards, and remember - I'm just around the corner to help you if you have questions! 🍷

EST 1884 USA

**F**

**First State Bank**  
Built on Belief

19575 US Highway 68 | Fayetteville  
937.393.9170

➔

**F** **fsb4me.com** **FDIC**

**WITHAMSVILLE**  
**WINNENSON**  
PLUMBING SUPPLY

**753-1121**

FAX: (513) 753-3130

- \* WATER HEATERS
- \* FAUCETS AND FCT. PARTS
- \* TOILETS AND TOILET PARTS
- \* TUBS AND WHIRLPOOLS
- \* SHOWERS AND ENCLOSURES
- \* PIPES, VALVES AND FITTINGS
- \* DELIVERING TO LAKE LORELEI

MON-FRI 7:30-5:00  
SAT 9:00-1:00

622 Ohio Pike  
Withamsville, Ohio

**TLC**  
**Construction & Design, LLC**  
Tim Carter, Owner

New Construction  
Remodeling/Additions

- Kitchen Cabinets
- Bathrooms
- Ceramic Tile
- Hardwood Flooring Installation

513-383-2941 (Cell) timcrtr7@aol.com

# Summer Gardens

*“The glory of gardening: hands in the dirt, head in the sun, heart with nature. To nurture a garden is to feed not just the body, but the soul.”*

– Alfred Austin

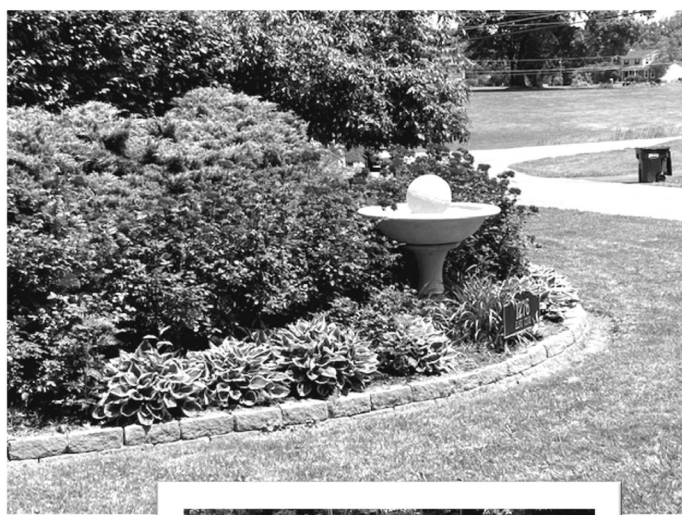



## Fayetteville Hardware & Supply, LLC



TOOLS  
PARTS  
NEW & USED EQUIPMENT



19535 U.S. 68  
Fayetteville, Ohio 45118

Tel. (513) 875-3030  
Fax (513) 875-2371

## ZUGG & Sons Repair SVC. LLC *car care center*

The Next Generation of Automotive Service  
*Specializing in Automotive Repair*

COMPUTERIZED DIAGNOSTIC EQUIPMENT

**513-875-2565**

4296 St. Rt. 131, Fayetteville

**Just 6 Minutes East of Lake Lorelei**

Hours: Monday-Friday 10:00-6:00

# LOTS MOWED / BUSH HOGGED

Residential and open lot  
mowing  
Brush Removal • Weed  
trimming  
Other lawn work requests

**All services and fees  
are negotiable**



**Please Call  
Doug Schmees**

Home: 513-875-2410  
Cell: 513-827-1436



*Serving The Tri State Area Since 1953*

(513) 791-2300 – AlamoElectronics.com

## All-Weather Outdoor TVs on display!

- Outdoor speakers and subwoofers
- Sonos Wireless Music Systems
- Smart Home Automation
- Home Audio music systems
- TV Mounting & Installation
- Knowledgeable Sales Staff
- Competitive Pricing

9572 Montgomery Road Cincinnati, OH 45242



## Donaldson Trucking & Excavating

*Local • Dependable • Experienced*

**Fill Dirt, Clay, Top Soil**

**Delivery or Pick Up Available**

**Land Clearing Ponds Drives**

**Grading Hauling**

**513-407-1018**

**Steven Donaldson Trucking**

# John Ipsaro Retires from BOT

Patricia Stirnkorb

## Saying “So Long”, but not “Goodbye”



As the saying goes, “there is nothing constant except change.” The Lake Lorelei Board of Trustees is experiencing that in this year’s election. In addition to Mike Hopkins, John Ipsaro is also retiring from the board.

John and his wife Heather have lived at the lake since 2007 when they spent the night at a friend’s house. They quickly fell in love with the area and what became their 2<sup>nd</sup> home, soon to be their full-time residence. As a lawyer, John had a skill set that was definitely needed and became a board member in 2010. He is currently serving as secretary and has been the liaison to the LLPOA’s outside legal counsel.

In looking back, and looking forward, John said the greatest need for the lake is absolutely the lake dredging project. Even though it has been brought before the community in the past, with no success in passing the measure, it is a must for the continued enjoyment of the lake. “Dredging the lake has been my passion since I started on the board. Even though we have failed, hopefully the next board will be successful. It must be done,” John said.

“There is a long list of things that have been completed in the last 11 years, among them is the budget which is always tight. “When I joined the board, we were looking at a \$150,000 shortfall on the annual budget. Now we run with an approximate \$50,000 surplus. While this sounds like a lot, for a community our size it is very small. But it is no longer a deficit.”

One of things that John also commented on are the renovations on lake properties and the way people take pride in their homes. That, of course, equates to our overall community life and the value of the homes in Lake Lorelei. It is a plus for all of us who live here.

There are new members who will be joining our Board of Trustees, and John’s advice to them: “Understand the diversity of the membership. We range from folks with million dollar-plus homes to folks on a fixed income. That diversity can make it very hard to build a consensus, particularly with respect to issues that impact member finances.”

John praised outgoing member Mike Hopkins who basically worked full time as an unpaid, highly dedicated, board member. He feels the current structure of the board is good because the work is divided by skill sets (engineers, finance, IT, etc.) He learned in the past years that board meetings have not been well attended, and that makes it difficult to communicate on both sides: from the homeowners to the board and vice versa.

For a mostly complete list (all that he could remember) of projects completed in the last 11 years, just take a look at these items:

- Gates (“A controversial topic for sure, but installing the gates resulted in over a \$100,000 annual swing in our finances. They have functioned erratically at times and inconvenienced folks at times. But the impact on LLPOA’s budget is enormous. And, if you haven’t yet, you should check with your insurance agent – I get a 15% savings on my HO insurance because I live in a “gated community.”)
- Bridge repair and guardrail installation this year (thank you John Wyman)
- Gladly Run mud wall fix (75K plus project) (thanks to many)
- Spillway repair (thank you George Mason)

- Control of the goose population (thank you again George Mason)
- New roof on the clubhouse and office
- Added new storage room addition for LLPOA records (thank you Bob Knueven)
- Front entrance renovated (Over 10K project financed completely with donations)
- New HVAC for the restaurant and clubhouse
- New Cooler for Marina
- New (for LLPOA) lake patrol pontoon boat
- Paving 80% of our roads at least once since 2010 (roughly 18 miles of 22 miles) (thank you Mike Hopkins and Allen Williams)
- All kinds of culvert replacement work including the big project at the entrance (thank you Mike Hopkins and Allen Williams)
- New salt bin (stronger, better construction) (thank you Bob Knueven)
- Rip-rapping of LLPOA properties (thank you Jimmy Johnson)
- Multiple new LLPOA docks installed and rented (thank you again Jimmy Johnson)
- Install electronic sign at entrance.
- Develop a comprehensive dredging plan (thank you John Wyman and many others)

“Our board of Trustees is an important part of the success in our Lake Lorelei community. We need to take note of the things they have accomplished and when it is time to vote, make sure we do so! Attend meetings and learn what each of us can do to contribute to our neighborhood.” Well said, John. ⚓

**“Gravel Guy”  
Trucking &  
Bobcat Service**



*Gravel, Soil, Sand, Mulch Delivered*  
Grading, Clean-up, Driveways, Heavy Use Pads,  
Drainage Problems Corrected

**513-519-4192**

**YOU'VE MADE IT!**

How do you make sure  
that you keep it?



**TOTAL  
WEALTH  
PLANNING**



**PLAN YOUR RETIREMENT**

With a fee-only fiduciary advisor who is required to act in your best interest. For a no-obligation, introductory meeting, contact Dave Wilder, CFP®

**TOTAL WEALTH  
PLANNING**

Visit [twpteam.com](http://twpteam.com) for more information about our firm and additional financial planning and investment management services

513.984.6696 | [info@twpteam.com](mailto:info@twpteam.com)



**B&C Total  
Chimney Care**

<ul style="list-style-type: none"> <li>◆ Animal Removal</li> <li>◆ Bird Screens &amp; Caps</li> <li>◆ Damper Repairs</li> <li>◆ Fire Box Masonry Repairs</li> </ul>	<ul style="list-style-type: none"> <li>◆ Flashing and Roof Repairs</li> <li>◆ Relining</li> <li>◆ Waterproofing Bricks</li> </ul>
---	---

**Dryer Vent Cleaning**

**(937) 382-3794**  
**Cell: (937) 302-6131**  
*Colossians: 3:23*

Since  
1987



# Lake Lorelei Property Association Financial Summary

## INCOME & EXPENSE SUMMARY THROUGH APRIL 2021

### MODIFIED CASH BASIS

\*NOTE: a detailed complete financial report is always available in the LL Office

#### Ordinary Income/Expense (Operations)

Income		
	Auto Decals	\$49,620.00
	Boat Inspections / Decals	35,800.00
	Dues & Services	197,051.00
	Initiation Fees	2,500.00
	Mowing & Chipping Fees	3,450.00
	Rents and Misc	44,310.00
<b>Total Income</b>		<b>\$332,731.00</b>
Expense		
	Personnel Expenses	
	Wages	\$67,864.00
	Payroll Taxes	6,915.00
	Employee Expenses	923.00
	Subcontractors	3,045.00
	<b>Total Personnel Expenses</b>	<b>78,747.00</b>
	Repairs & Maintenance <sup>1</sup>	299,741.00
	Supplies	3,410.00
	Property Taxes	6,435.00
	Utilities	15,096.00
	Other Expenses (Combined)*	111,499.00
<b>Total Expense</b>		<b>\$514,928.00</b>
<b>Excess cash receipts over disbursements</b>		<b>-\$182,197.00</b>

\*Total Other Expenses (Combined) includes accounting fees, fuel, insurance, postage, printing, professional fees among others

<sup>1</sup> Repairs and Maintenance includes Bridge and Dam roadway expenses not yet reimbursed/reconciled to Road Assessment funds.

#### ROAD ASSESSMENT ACCOUNT THROUGH 31 MARCH, 2021

Beginning Balance		\$337,474.00
Road Assessment Collected <sup>1</sup>		69,335.00
<b>Subtotal</b>		<b>406,809.00</b>
Expenditures		
Paving Contractor		0.00
Maintenance <sup>2</sup>		189,491.00
Transfer to Ops Labor & Material <sup>3</sup>		0.00
<b>Total Expenditures</b>		<b>189,491.00</b>
<b>Ending Balance (as of 31 March)</b>		<b>\$217,318.00</b>

<sup>1</sup> includes building permit collections and Rumpke contribution

<sup>2</sup>For expenses in support of road repair (culvert replacement, cold patch, salt, etc.)

<sup>3</sup>For labor or materials dispensed from main account.

NOTE: Beginning balance begins Jan 1, 2021

NOTE: \$102,904.54 in Republic money market fund.



# Popeye & the Lake Safety Patrol WANT YOU!!

Volunteer to observe Lake activities, or operate the patrol boat.

1-1/2 Hour Shifts available.

Meet your neighbors on the water and help to educate all on boater safety.

Contact Pete Zawaly at 614-216-1798 or [pzawaly@zawalylaw.com](mailto:pzawaly@zawalylaw.com) for more information.

## Welcome New Neighbors!

*\*Compiled from the LL Office records in the last six months*

- Andrew & Amaris Blasek
- Morris Combs
- Daren Davidson
- Shawn Simes & Hannah Dunn
- Craig & Kris Eisentrout
- Roger L Frommling Jr.
- Kathleen & Mark Haberer
- Sean & Deborah Langdon
- Bryan & Jamie Lansaw
- Van J. & Janice L. Michael
- William & Darlene Nartker
- Larry & Heidi Overbee
- Michelle Pennington
- Christin & Eric Petzold
- Arthur Richmond
- The Roger Family
- Joseph T Sturgill
- Richard Austin Tieke
- Jeffrey & Monica Troy
- Lisa & Joshua Zelvy



**SIBCY CLINE**  
REALTORS®

**William Kidwell**

Realtor®  
NAR  
OAR  
SOAR

OFFICE: (513) 248-0800  
VOICE: (513) 786-9568  
CELL: (513) 910-8947  
EMAIL: [wkidwell@sibcyclyne.com](mailto:wkidwell@sibcyclyne.com)



1077 State Route 28 • Suite 111 • Milford, Ohio 45150  
Web Site: <http://www.sibcyclyne.com>

Tell them you saw it in the LEGEND

# BUY LOCAL!

## Support the Legend's Advertisers

## WE ARE THE WILDLIFE CONTROL EXPERTS



[varmentguard.com](http://varmentguard.com) 877.571.7100

**Promote your business to  
Lake Lorelei's members  
2021 Schedule**

ISSUE	CLOSING DATE
July / Aug	June 16, 2021
Sept / Oct	Aug 18, 2021
Nov / Dec	Oct 20, 2021
Jan / Feb 22	Dec 15, 2021

**2021 Advertising Rates**

**Business Card** (3-3/4" x 2-1/4") **\$25**

**1/4 Page** (3-3/4" x 4-5/8") **\$45**

**1/2 Page** (7-5/8" x 4-5/8") **\$80**

**Full Page** (7-5/8" x 9-1/2") **\$150**

Contact: Martha Wallace  
Email: thelegend@lakelorelei.ohio.com  
513.257.6230



Please like and Follow us at  
"Lake Lorelei Property Owners Association"

LLPOA's only approved Facebook Page

**Disclaimer**

Any opinion expressed in The Legend reflects only the opinion of the author and not the LLPOA, the Board of Trustees, the staff of The Legend, or any other person.

Advertising in The Legend is not an endorsement of products or services. The Legend staff reserves the right to reject the submissions for publication.

**Mission Statement**

The Booster Club was organized in 1968 to provide information on official and social activities of interest. The Legend is not an arm of the Board of Trustees but an independent publication approved by the Board of Trustees and is committed to serving the members of the Lake Lorelei Property Owners Association.

The Legend is a private newsletter funded for Lake Lorelei through commercial advertisers.

**SAVE THIS NOTICE!  
It may save your life**

- \* Pick up a map at the office and circle your location on the lake (with letters).
- \* Determine the SHORTEST distance from Fayetteville to your house – through the **FRONT GATE** or the **BACK GATE**.
- \* When calling 911, instruct the operator to dispatch the Life Squad through the **FRONT GATE** or **BACK GATE**.

**Community Contacts**

**Office**

**Phone**

**Office**

**Phone**

Brown County Animal Shelter 937-378-3457  
Brown County Health Department 937-978-6892  
Brown County Sheriff's Department 937-378-4435  
Brown County Veteran's Service 937-378-3155  
Bureau of Motor Vehicles 937-378-4779  
Duke - Power Outage 800-543-5599  
Duke Energy Customer Service 800-544-6900  
Fayetteville Fire Department 513-875-2202

Fayetteville Police 513-875-3535  
Fayetteville Public Library 513-274-2665  
Fayetteville Schools 513-875-2423  
Fayetteville-Perry Sewer District 513-875-4600  
Post Office - Fayetteville 513-875-3740  
Rumpke Customer Service 800-828-8171  
Spectrum Customer Service 855-707-7328  
Western Water 513-722-1682

**Lake Lorelei Board of Trustees**

Embracing the past ~ Managing the present ~ Focused on the future

		<b>Term</b>	<b>End</b>	<b>Phone</b>	<b>Email</b>
<b>President</b>	Rick Connors	2023		952-250-9790	rick.connors@lakelorelei.ohio.com
<b>Vice-President</b>	Jimmy Johnson	2023		513-875-3715	jimmy.johnson@lakelorelei.ohio.com
<b>Treasurer</b>	Todd Steinbrink	2022		513-793-9217	todd.steinbrink@lakelorelei.ohio.com
<b>Secretary</b>	Denis Behm	2022		513-673-8422	denis.behm@lakelorelei.ohio.com
<b>Trustees:</b>	Kathryn Greene	2024		513-460-4947	kathryn.greene@lakelorelei.ohio.com
	Rick Hosea	2023		513-875-8304	rick.hosea@lakelorelei.ohio.com
	James Padgett	2024		513-266-3949	james.padgett@lakelorelei.ohio.com
	Bruce Simeone	2024		513-518-0073	bruce.simeone@lakelorelei.ohio.com
	John Wyman	2022		513-827-0074	john.wyman@lakelorelei.ohio.com

**Lake Restaurant**

**Sandy's Beach Bar & Grill**

To Order Call

**513-875-4992**

\*\*\*\*\*  
 For more information on Lake Lorelei,  
 visit **www.lakelorelei.ohio.com**  
 \*\*\*\*\*

**Have Something to Say??**

The Legend wants to hear from you!



- \* Send a Letter to the Editor
- \* Write an article
- \* Report on family events (Community Corner)

Your suggestions and ideas are always welcome!  
 We will do our best to publish all appropriate content.

*The Editor reserves the right to make minor copy-editing changes, per accepted standards for punctuation, spelling, capitalization and usage. The Editor may adapt any submitted copy to conform as needed with the current publication layout and design standards.*

**Email: TheLegend@lakelorelei.ohio.com**

**Lake Lorelei Office**

Phone: **513-875-3435**

Fax: 513-875-4244

**Summer Office Hours**

Tuesday through Friday: 1 - 5pm  
 Saturday: 9 AM - 12 PM

*If assistance is needed outside these hours, please call the office and we will make every effort to accommodate our residents.*

**Lake Director:** Chris Kwiatkowski  
 director@lakelorelei.ohio.com

**Member Coordinator:** Tonya Lavatori  
 membercoordinator@lakelorelei.ohio.com

LLPOA accepts



**2021 LLPOA Board Meeting Schedule**

JAN	FEB	MAR	APR	MAY	JUN	JUL	AUG	SEP	OCT	NOV	DEC
	Quarterly Meeting		Annual Meeting	Quarterly Meeting	Spring Town Meeting		Quarterly Meeting		Fall Town Meeting	Quarterly Meeting	
No Meet	18 FEB	No Meet	10 APR	20 MAY	12 JUN	No Meet	19 AUG	No Meet	9 OCT	18 NOV	No Meet

***The Legend of Lorelei***  
**PO Box 363**  
**Fayetteville, Ohio 45118**

PRESORT STD  
U.S. POSTAGE  
**PAID**  
CINCINNATI, OH  
PERMIT NO. 770

**Copy/ADV Deadline for the Sept/Oct 2021 Legend is  
August 18, 2021**  
**Email: [thelegend@lakeloreleiohio.com](mailto:thelegend@lakeloreleiohio.com)**

JOIN US This Summer for

**Card & Game Night at the Clubhouse!**  
**Tuesdays, July 13th and August 10th**  
(Adults Only)



**Play with Old or New Friends!**

Try Poker, Hand & Foot, Hearts, Bridge,  
Chess, Scrabble, Mahjongg...or Whatever  
*Bring your cards & games or play with ours!*

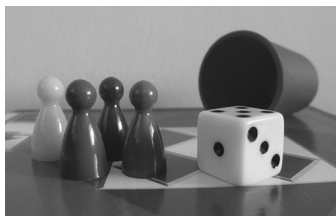

**The FUN starts at 7 PM**  
**Door Prizes!**



**Snacks and Soft Drinks provided by  
The Women's Club**